

Balluff linear
position sensors

OVERVIEW AND SELECTION GUIDE

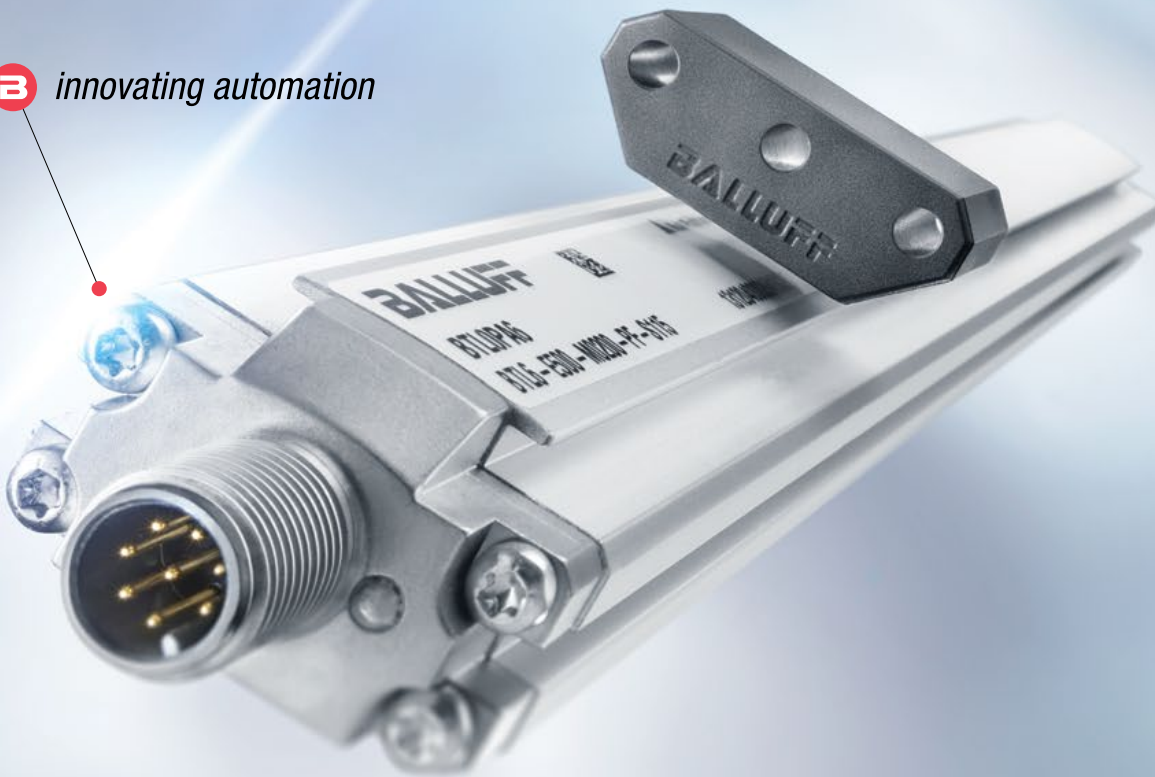

B *innovating automation*



Superior technology, features that matter,
rigorous testing, global reach

THE BALLUFF ADVANTAGE

 *innovating automation*

Balluff linear position sensors have achieved a worldwide reputation for accuracy, stability, and rock-solid reliability. This doesn't happen by chance. Linear position sensors are designed from the ground up to exceed expectations in demanding industrial environments. Balluff understands that quality, performance, and reliability are only part of the story. Diverse applications require diverse products with features that enhance usability and improve process efficiency.

- Industry-proven magnetostrictive technology
- Rigorous, uncompromising quality testing
- Usability features that really matter
- Standard and specialty form factors to cover virtually any application requirement
- Balluff's global presence means worldwide support and service
- Industry-leading delivery including unmatched same-day and next-day expediting
- Not just linear position sensing: Balluff's extensive offerings of industrial sensors and systems provide complete solutions



Magnetostrictive technology – a superior non-contact sensing principle

Magnetostriction is a property of ferromagnetic (iron-based, magnetizable) materials that causes them to change their shape or dimensions in the presence of a magnetic field. In addition to numerous other practical uses, the magnetostrictive effect is ideally suited for use in industrial linear position measurement sensors.

Magnetostrictive linear position sensors use an iron-alloy sensing element, typically called a waveguide. Referring to the diagram below, the waveguide **1** is housed inside a pressure-rated stainless steel tube or an aluminum extrusion. The position magnet **2** is attached to the moving part of the machine, or the piston of a hydraulic or pneumatic cylinder.

Measurements are initiated by applying a short-duration electrical pulse to a conductor **3** attached to the waveguide. The current creates a magnetic field **4** along the waveguide.

The magnetic field from the position magnet interacts with the generated magnetic field, inducing a torsional mechanical strain on the waveguide. When the current pulse stops the strain is released, causing a mechanical pulse to propagate along the waveguide. This mechanical pulse travels at a constant speed and is detected at the signal converter **5**.

The time between the initial electrical pulse and the received mechanical pulse accurately represents the absolute position of the position magnet and, ultimately, the position of the machine or hydraulic cylinder. The position of the magnet along the waveguide is calculated by accurately timing the interval between the initial current pulse, also known as the Interrogation Pulse, and the detection of the mechanical return pulse.

Rugged and Wear-Free

- No mechanical contact between magnet and sensing element
- Immune to dirt, dust, and other potential contaminants
- Available in many different form factors for many different applications

Absolute

- Resulting time measurement represents absolute position of machine
- Available in many analog and digital interface types
- No need to re-home after power interruption

Accurate

- Can detect position changes as small as 1 micrometer (1/1000th of a millimeter)
- Absolute positional accuracy to ± 30 micrometers

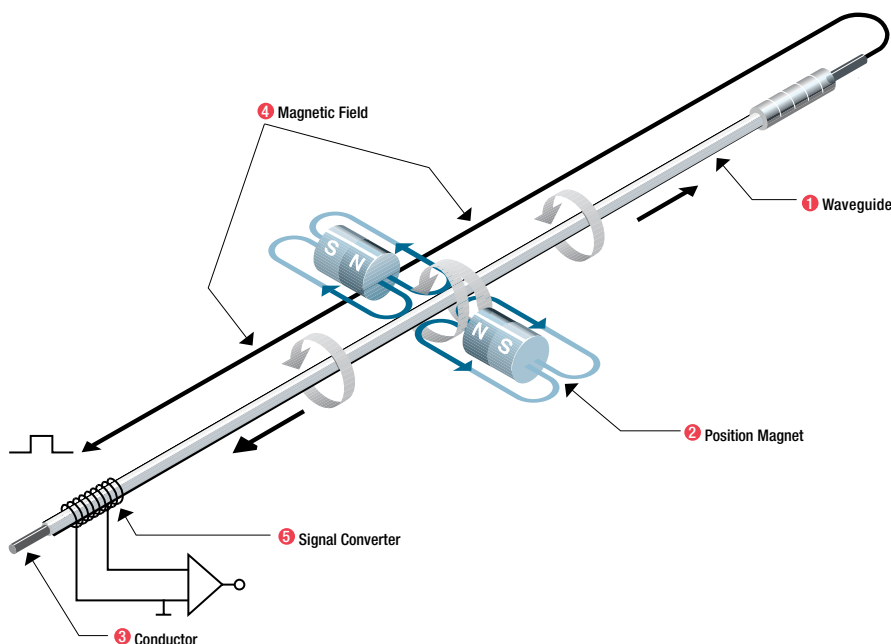

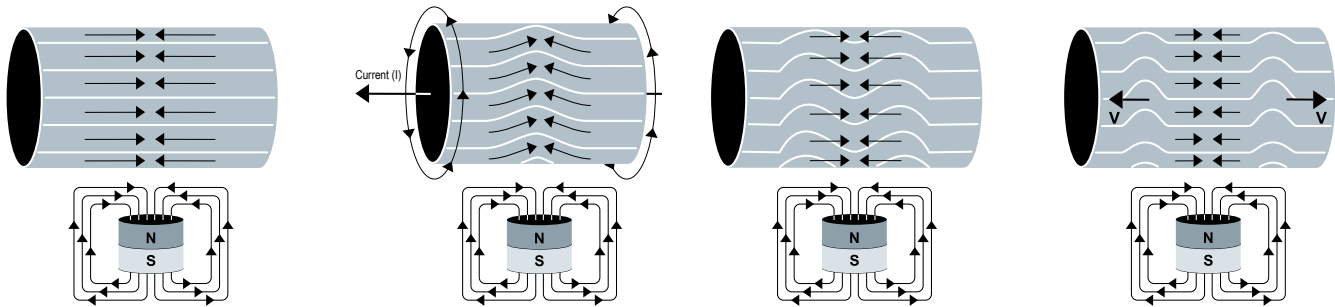

INITIAL CONDITION

The waveguide tube is magnetized only at the position of the permanent, moving magnet. In practice, the permanent magnet is attached to the moving part of the machine or the piston of a hydraulic or pneumatic cylinder.

CURRENT PULSE APPLIED

A short duration, (1-3 μ sec) current pulse is applied to the waveguide conductor. The magnetic field of the permanent magnet and the magnetic field created by the current pulse interact, causing torsional deflection of the waveguide element.

CURRENT PULSE TURNED OFF

The torsion on the waveguide element abruptly relaxes, and the mechanical wave propagation begins.

WAVE PROPAGATION

The mechanical wave propagates in both directions along the waveguide at a nominal velocity of 2850 meters/second. The detection of the mechanical wave in the signal converter completes one measurement cycle. Measurement cycles are typically repeated at rates of 0.5 to 5 milliseconds, depending on the length of the sensor.

DEXYÍ

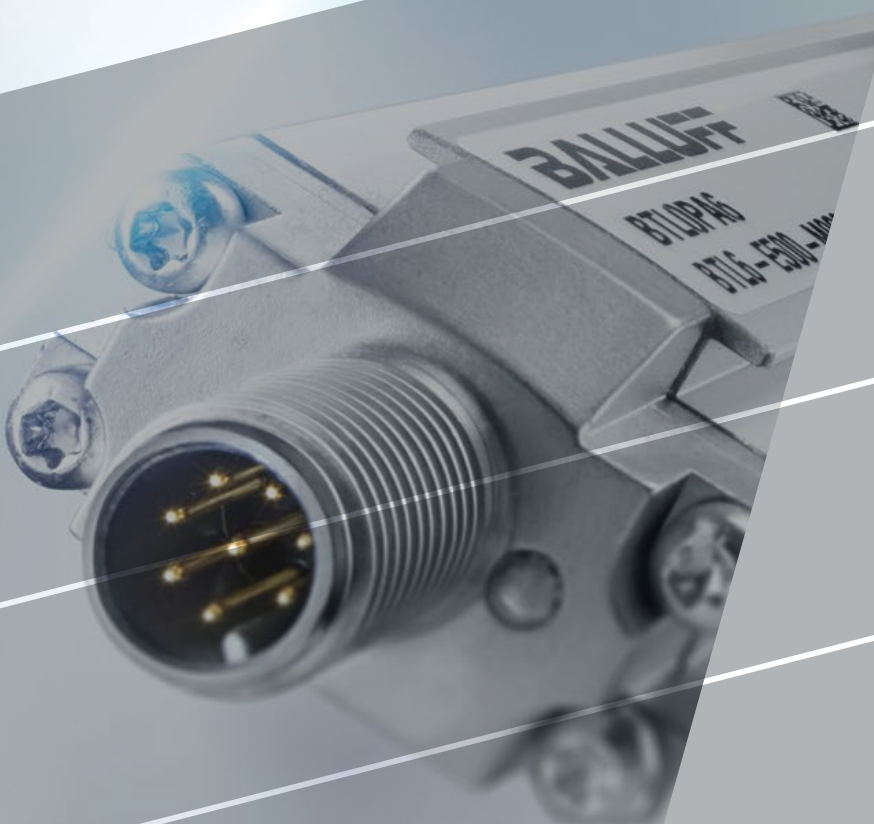

CONTENTS

10

**STANDARD HYDRAULIC
IN-CYLINDER ROD-STYLE
LINEAR POSITION SENSORS**



- 10 Standard hydraulic in-cylinder rod-style
- 12 IO-Link interface
- 14 Ethernet interfaces
- 16 Synchronous Serial Interface (SSI)
- 18 Analog interface
- 20 Digital pulse interface

22

**RUGGED/SPECIAL DUTY
IN-CYLINDER ROD-STYLE
LINEAR POSITION SENSORS**



- 22 Rugged/special duty in-cylinder rod-style
- 24 Synchronous Serial Interface (SSI)
- 26 Analog interface
- 28 Digital pulse interface

30

**HAZARDOUS AREA
ROD-STYLE
LINEAR POSITION SENSORS**

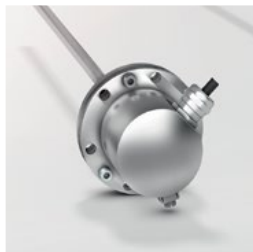

- 30 Hazardous area rod-style
- 32 Bolt-in ex-proof TA12 – Analog interface
- 34 Bolt-in ex-proof TA12 – Synchronous Serial Interface (SSI)
- 36 Bolt-in ex-proof TA12 – Digital pulse interface
- 38 Thread-in ex-proof – Analog interface
- 40 Thread-in ex-proof – Synchronous Serial Interface (SSI)
- 42 Thread-in ex-proof – Digital pulse interface
- 44 ATX / IECEx increased safety (NEX) – Analog interface
- 46 ATX / IECEx increased safety (NEX) – Synchronous Serial Interface (SSI)
- 48 ATX / IECEx increased safety (NEX) – Digital pulse interface

50

**EXTERNAL-MOUNT
PROFILE-STYLE
LINEAR POSITION SENSORS**



- 50 External-mount profile-style
- 52 Standard profile-style – Ethernet interfaces
- 54 Standard profile-style – Analog interface
- 56 Standard profile-style – Synchronous Serial Interface (SSI)
- 58 Standard profile-style – Digital pulse interface
- 60 Low profile-style – IO-Link interface
- 62 Low profile-style – Analog interface
- 64 Tubular profile-style – Analog interface
- 66 Tubular profile-style – Digital pulse interface

68

**ACCESSORIES
AND CONNECTIVITY**



- 70 Magnets and floats
- 72 Cables

WARNING

- Read, understand, and follow warnings and manual. Failure to do so could result in serious injury or death.
- NEVER USE AS A SENSING DEVICE FOR PERSONNEL PROTECTION
- Does NOT include self-checking redundancy circuitry required for use in personnel safety applications
- Does NOT meet OSHA and ANSI standards for point-of-operation devices

Balluff linear position sensors

PRODUCT LINE OVERVIEW



SERIES	STANDARD HYDRAULIC IN-CYLINDER ROD-STYLE	RUGGED/ SPECIAL DUTY IN-CYLINDER ROD-STYLE (THREAD-IN)	RUGGED/ SPECIAL DUTY IN-CYLINDER ROD-STYLE (BOLT-IN)	RUGGED/ SPECIAL DUTY IN-CYLINDER ROD-STYLE (IP69K-RATED)
--------	---	--	--	--

In-cylinder rod-style version	■	■	■	■
External mount version (e.g. on machine frames)				
Fill level sensor (e.g. precision dispensing systems)				
Special approvals				
Magnet	Ring or float	Ring or float	Ring or float	Ring or float
Multi-Magnet	■			

INTERFACES

Analog voltage – 0...10 V, 10...0 V, –10 V...10 V	■	■	■	■
Analog current – 4...20 mA, 0...20 mA	■	■	■	■
Synchronous Serial Interface (SSI)	■	■	■	■
EtherCAT	■			
IO-Link				
CANopen	Refer to website			
DeviceNet	Refer to website			
Profibus DP	Refer to website			
Start/stop pulse interface	Refer to website			
VARAN	Refer to website			



HAZARDOUS AREA EX-PROOF ROD-STYLE (BOLT-IN)



HAZARDOUS AREA EX-PROOF ROD-STYLE (THREAD-IN)



HAZARDOUS AREA INCREASED SAFETY ROD-STYLE (THREAD-IN)

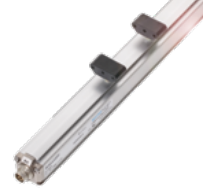

EXTERNAL-MOUNT STANDARD PROFILE-STYLE

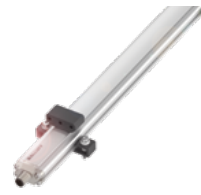

EXTERNAL-MOUNT LOW PROFILE-STYLE

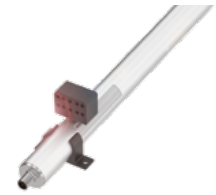

EXTERNAL-MOUNT TUBULAR PROFILE (AT)

	■	■	■			
				■	■	■
Potentially explosive operation	Potentially explosive operation	Potentially explosive operation				
Flameproof "d" zone 0, zone 1, ATEX, NEC, CSA, IECEX	Flameproof "d" zone 0, zone 1, ATEX, KOSHA, GOST, IECEX	Protection type "n" zone 2				
Ring or float	Ring or float	Ring or float	Floating/captive	Floating/captive	Floating	
			■		■	
■	■	■	■	■	■	■
■	■		■			
			■			■
				■		
30	30	30	50	50	50	

Standard hydraulic in-cylinder rod-style sensors

The industry standard for hydraulic cylinder position feedback

Advanced design, superior performance, and ultimate versatility make Balluff standard rod-style linear position sensors the ideal choice for high-performance hydraulic cylinder position feedback. They are exceptionally well-suited for use in hydraulic cylinders used in industries such as steel processing, lumber and tire manufacturing.

Balluff rod-style linear position sensors installed into hydraulic cylinders withstand high pressure operation up to 8700 psi (600 bar), and are available in measuring lengths from 2" to 300" (50 mm to 7620 mm). Numerous electrical interface options are available to adapt to any control system.

Features

- IO-Link, Ethernet, SSI, Analog, and Digital Pulse interface versions available
- Integrated status LEDs for condition monitoring and diagnostics
- Pressure-rated to 600 bar (8700 psi)
- Stroke lengths to 7620 mm (300")
- Operating temperatures -40 °C to +85 °C



STANDARD SAE THREADS

The industry-standard for position feedback in hydraulic cylinders

Features

- 3/4"-16 UNF mounting threads
- Pressure rated to 600 bar (8700 psi)
- Stroke lengths to 7620 mm

Page 12-21



METRIC THREADS

Standard in-cylinder rod-style for metric-threaded cylinders

Features

- M18 x 1 mounting threads
- pressure rated to 600 bar (8700 psi)
- Stroke lengths to 7620 mm

Page 12-21



RRM – RAPID REPLACEMENT MODULE

Reduce downtime and simplify field repairs with the Rapid Replacement module option (RRM).

Features

- Pressure tube stays in cylinder
- No need to de-pressurize the system
- No chance for oil spillage
- Available in analog and SSI interface versions
- available with 3/4"-16 UNF or metric M18 x 1 mounting threads

Page 16-19

Standard hydraulic cylinder rod-style

IO-LINK INTERFACE

Advanced functionality and network connectivity

Standard rod-style linear position sensors with IO-Link interface offer advanced functionality and performance compared to more traditional analog interfaces.

The IO-Link v1.1 interface allows for fast data transmission, integrated sensor-level diagnostics, and simplified, economical connections to nearly any industrial fieldbus system.

Features

- Precise machine positioning with 5 μm resolution
- Simultaneous position and speed measurement in one system
- Fast update time and data transmission with IO-Link
- Time-saving startup and flexible customizing with IO-Link
- Non-contact and wear-free, insensitive to contamination

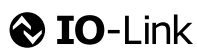



STANDARD IN-CYLINDER ROD-STYLE IO-LINK INTERFACE SPECIFICATIONS



Measured variable	Position and velocity
Measuring range	25...4572 mm
Available interfaces	IO-Link 1.1
Non-linearity	$\pm 50 \mu\text{m}$
Resolution	5 μm
Supply voltage	18...30 Vdc
Operating temperature	-40...+85 °C
Shock rating	100g/6 ms as per EN 60068-2-27
Vibration rating	12g, 10...2000 Hz as per EN60068-2-6
Operating pressure	600 bar (pressure tube portion)
Environmental rating	IP67



HOW TO ORDER

Ordering example: **BTL6-U101-M**  **-**  **-S4**

Standard nominal stroke [mm]
0025...4572 in 1 mm increments

Design / Mounting threads

- B Metric, M18x1.5 mounting threads
- Z Standard 3/4"-16 UNF mounting threads

Standard hydraulic cylinder rod-style

ETHERNET INTERFACES

Advanced functionality – direct network connectivity

Standard rod-style linear position sensors with Ethernet interfaces offer uniform, simple wiring, integrated sensor-level diagnostics, and direct connection to the most commonly-used Ethernet-based industrial fieldbus systems. Flexible magnet mode (FMM) allows the sensor to automatically detect up to 16 position magnets and configure itself accordingly. The integrated internal web server makes sensor set-up and troubleshooting fast and easy.

Features

- Fast, accurate position and velocity measurement
- Non-contact and wear-free, insensitive to contamination
- Flexible magnet mode (FMM) automatically adjusts for number of position magnets in use
- Synchronous, real-time data
 - Ethernet/IP** – CIP-Sync
 - Profinet** – IRT
 - EtherCAT** – Distributed clock
- Integrated web server for easy set-up and troubleshooting



STANDARD IN-CYLINDER ROD-STYLE ETHERNET INTERFACE SPECIFICATIONS



Measured variable	Position and velocity
Measuring range	25...7620 mm
Available interfaces	Ethernet/IP EtherCAT PROFINET
Non-linearity	$\pm 50 \mu\text{m} \leq 500 \text{ mm nominal stroke}$ $\pm 0.02\% > 5500 \text{ mm nominal stroke}$
Resolution	1 μm
Supply voltage	10...30 Vdc
Operating temperature	-40...+85 °C
Shock rating	150g/6 ms as per EN 60068-2-27
Vibration rating	20g, 10...2000 Hz as per EN60068-2-6
Operating pressure	600 bar (pressure tube portion)
Environmental rating	IP67



HOW TO ORDER

Ordering example: **BTL7-V50** - **M** **-----** - **C003**

Interface

- T PROFINET RT
- E EtherCAT
- D Ethernet/IP

Design / Mounting threads

- Z SAE standard 3/4"-16 UNF threads
- B Metric M18x1.5 threads

Standard nominal stroke [mm]

0025...7620 in 1 mm increments

Standard hydraulic cylinder rod-style

SYNCHRONOUS SERIAL INTERFACE (SSI)

Standard rod-style linear position sensors with Synchronous Serial Interface (SSI) offer high accuracy and fast update times necessary for dynamic closed-loop motion control applications.

SSI transducers are available in both standard and USB configurable versions. The standard version offers 100% backward compatibility to legacy Balluff SSI sensors, while the USB configurable version offers advanced user-configuration options via the PC-based configuration tool. Both versions offer position resolution down to 1 μm , and stroke lengths to 7620 mm (300 inches).

Features

- Position resolution to 1 μm
- Non-linearity of $\pm 30 \mu\text{m}$
- Synchronous or asynchronous operation
- Binary and gray code versions

SSI

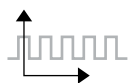

STANDARD IN-CYLINDER ROD-STYLE SYNCHRONOUS SERIAL INTERFACE (SSI) SPECIFICATIONS



Measured variable	Position (standard version) Position and velocity (USB configurable version)
Measuring range	25...7620 mm
Available outputs	Synchronous Serial Interface (SSI) Binary or gray code, 24 bit, 25 bit, 26 bit
Non-linearity	$\pm 30 \mu\text{m}$ with 5 and 10 μm resolution or $\leq \pm 2$ LSB
Resolution	1,2,5,10,20,40,50, or 100 μm
Supply voltage	10...30 Vdc
Operating temperature	-40...+85 °C
Shock rating	150g/6 ms as per EN 60068-2-27
Vibration rating	20g, 10...2000 Hz as per EN60068-2-6
Operating pressure	600 bar (pressure tube portion)
Environmental rating	IP67 (connector versions) IP68 (integral cable versions)



HOW TO ORDER STANDARD VERSION

Ordering example: **BTL7 - S5**  **- M**  **-**  **-** 

Data format

- 0 Binary code rising (24-bit)
- 1 Gray code rising (24-bit)
- 6 Binary code rising (25-bit)
- 7 Gray code rising (25-bit)
- A Binary code rising (26-bit)
- B Gray code rising (26-bit)

Resolution

- 1 1 µm
- 2 5 µm
- 3 10 µm
- 4 20 µm
- 5 40 µm
- 6 100 µm
- 7 2 µm
- 8 50 µm

Connection

- S115 Connector 8-pin M12
- S32 Connector 8-pin M16 (DIN)
- KA02 PUR cable 2 m
- KA05 PUR cable 5 m
- KA10 PUR cable 10 m
- KA15 PUR cable 15 m

Design / Mounting threads

- Z Standard 3/4"-16 UNF mounting threads
- ZM Standard rapid replacement module (RRM) option
- B Metric, M18x1.5 mounting threads
- BM Metric, rapid replacement module (RRM) option





Standard nominal stroke [mm]

0025...7620 in 1 mm increments

Synchronous / Asynchronous operation

- [blank] Asynchronous, output value at null point = 0
- B Synchronous, output value at null point = 0

HOW TO ORDER USB CONFIGURABLE VERSION

Ordering example: **BTL7 - S510**  **- M**  **-**  **-** 

Connection

- S115 Connector 8-pin M12
- S32 Connector 8-pin M16 (DIN)
- KA02 PUR cable 2 m
- KA05 PUR cable 5 m
- KA10 PUR cable 10 m
- KA15 PUR cable 15 m

Design / Mounting threads

- Z Standard 3/4"-16 UNF mounting threads
- ZM Standard rapid replacement module (RRM) option
- B Metric, M18x1.5 mounting threads
- BM Metric, rapid replacement module (RRM) option

Standard nominal stroke [mm]

0025...7620 in 1 mm increments

Synchronous / Asynchronous operation

- [blank] Asynchronous, output value at null point = 0
- B Synchronous, output value at null point = 0

Standard hydraulic cylinder rod-style

ANALOG INTERFACE

Balluff standard rod-style linear position sensors with analog interface are the ideal choice for hydraulic cylinder position monitoring applications across a variety of markets and industries. Industry-standard 0-10V, and 4 to 20 mA signals are available. Operating stroke ranges can be user-scaled for maximum versatility.

Features

- Analog voltage or current versions available
- Field-scalable stroke length via included push-button teach tool (standard version)
- Advanced field set-up, scaling, and configuration (USB configurable version)
- Integrated status LEDs for condition monitoring and diagnostics
- Stroke lengths to 7620 mm

ANALOG





STANDARD IN-CYLINDER ROD-STYLE ANALOG INTERFACE SPECIFICATIONS



Measured variable	Position (standard version) Position and velocity (USB configurable version)
Measuring range	25...7620 mm
Available outputs	0...10V/10...0V, -10...10V/10...-10V, 0... mA, 4...20 mA
Non-linearity	±50 µm ≤ 500 mm nominal stroke ±0.01% 501...5500 mm nominal stroke ±0.02% > 5500 mm nominal stroke
Resolution	System resolution/min. 2 µm
Supply voltage	10...30 Vdc
Operating temperature	-40...+85 °C
Shock rating	150g/6 ms as per EN 60068-2-27
Vibration rating	20g, 10...2000 Hz as per EN60068-2-6
Operating pressure	600 bar (pressure tube portion)
Environmental rating	IP67 (connector versions) IP68 (integral cable versions)

HOW TO ORDER STANDARD VERSION

Ordering example: **BTL7 - 5 0 - M**  -  - 

Output signal

- A 0...10 V and 10...0 V
- G -10...10 V and 10...-10 V
- E 4...20 mA or 20...4 mA
- C 0...20 mA or 20...0 mA

Output signal characteristic

- 1 Rising and falling (output types A and G only)
- 0 Rising (output types C and E only)
- 7 Falling (output types C and E only)

Connection

- S115 Connector 8-pin M12
- S32 Connector 8-pin M16 (DIN)
- KA02 PUR cable 2 m
- KA05 PUR cable 5 m
- KA10 PUR cable 10 m
- KA15 PUR cable 15 m

Design / Mounting threads

- Z Standard 3/4"-16 UNF mounting threads
- ZM Standard rapid replacement module (RRM) option
- B Metric, M18x1.5 mounting threads
- BM Metric, rapid replacement module (RRM) option

Standard nominal stroke [mm]

0025...7620 in 1 mm increments

HOW TO ORDER USB CONFIGURABLE VERSION

Ordering example: **BTL7 - 501 - M**  -  - 

Output signal

- A 0...10 V and 10...0 V
- E 4...20 mA or 20...4 mA

Connection

- S115 Connector 8-pin M12
- S32 Connector 8-pin M16 (DIN)
- KA02 PUR cable 2 m
- KA05 PUR cable 5 m
- KA10 PUR cable 10 m
- KA15 PUR cable 15 m

Design / Mounting threads

- Z Standard 3/4"-16 UNF mounting threads
- ZM Standard rapid replacement module (RRM) option
- B Metric, M18x1.5 mounting threads
- BM Metric, rapid replacement module (RRM) option

Standard nominal stroke [mm]

0025...7620 in 1 mm increments

Standard hydraulic cylinder rod-style

DIGITAL PULSE INTERFACE

Balluff linear position sensors with digital Start/Stop interfaces allow simple connection to control systems with compatible Start/Stop interface hardware. The RS-485 differential signal provides excellent noise immunity and allows sensor-to-controller cable lengths up to 500 meters.

Features

- Noise immune RS-485 signal transmission
- Stroke lengths to 7620 mm
- Position resolution to 1 μm (controller dependent)

DIGITAL PULSE



STANDARD IN-CYLINDER ROD-STYLE DIGITAL PULSE INTERFACE SPECIFICATIONS



Measured variable	Position
Measuring range	25...7620 mm
Available outputs	DPI/IP Start/Stop Pulse Interface
Non-linearity	$\pm 50 \mu\text{m} \leq 500 \text{ mm}$ nominal stroke $\pm 0.01\% 501 \dots 5500 \text{ mm}$ nominal stroke $\pm 0.02\% > 5500 \text{ mm}$ nominal stroke
Resolution	1 μm
Supply voltage	10...30 Vdc
Operating temperature	-40...+85 °C
Shock rating	150g/6 ms as per EN 60068-2-27
Vibration rating	20g, 10...2000 Hz as per EN60068-2-6
Operating pressure	600 bar (pressure tube portion)
Environmental rating	IP67 (connector versions) IP68 (integral cable versions)

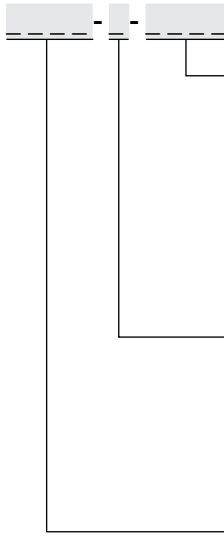

HOW TO ORDER

Ordering example: **BTL7 - P511 - M** 

Connection

- S115 Connector 8-pin M12
- S32 Connector 8-pin M16 (DIN)
- KA02 PUR cable 2 m
- KA05 PUR cable 5 m
- KA10 PUR cable 10 m
- KA15 PUR cable 15 m

Design / Mounting threads

- Z Standard 3/4"-16 UNF mounting threads
- ZM Standard rapid replacement module (RRM) option
- B Metric, M18x1.5 mounting threads
- BM Metric, rapid replacement module (RRM) option

Standard nominal stroke [mm]

0025...7620 in 1 mm increments

Rugged/special duty in-cylinder rod-style

Rod-style linear position sensors for demanding applications

Compact, rugged, and built to survive, Balluff linear position sensors are available with full stainless steel housing construction. Balluff's rugged linear position sensors are available in protection classes up to IP69K and for high pressure cylinder applications up to 1000 bar. Their non-contact working principle prevents wear and ensures almost unlimited service life. Therefore, Balluff offers you a high degree of reliability and precision, even under the most extreme ambient conditions.

Features

- Rugged stainless steel housing
- Thread-in or bolt-in designs available
- Exceptionally shock and vibration resistant
- Environmentally protected up to IP69K
- Temperature range of -40 to +85 °C
- High-pressure resistant rated to 1000 bar
- Resolution to 1 µm
- Measuring lengths up to 7620 mm
- Non-contact, wear-free measurement technology



RUGGED HOUSING – THREAD-IN

Featuring a full stainless steel housing and industry-standard mounting threads, the W/H style is designed to perform in demanding applications where physical damage and/or caustic chemicals pose challenges for standard sensors.

Features

- 3/4"-16 UNF or M18 x 1 mounting threads
- Stroke lengths 7620 mm
- Available interfaces include analog, Synchronous Serial Interface (SSI), and digital Start/Stop
- Rear-exit or side-exit connector and cable versions available

Page 22-29



RUGGED HOUSING – BOLT-IN

The K style linear position sensor features a compact, full stainless steel housing, and is designed to be bolted into hydraulic cylinders. The bolt-in design offers unmatched protection against damage caused by mechanical impact.

Features

- Threadless, bolt-in design
- Stroke lengths 7620 mm
- Available interfaces include analog, Synchronous Serial Interface (SSI), and digital Start/Stop
- Rear-exit or side-exit connector and cable versions available

Page 22-29



IP69K-RATED HOUSING

With a hermetically sealed, full stainless steel housing designed to withstand pressure-directed washdown, the HB/WB style is ideal for demanding applications exposed to adverse conditions.

Features

- 3/4"-16 UNF or M18 x 1 mounting threads
- Optional cable protection system protects against cable damage
- Available interfaces include analog, Synchronous Serial Interface (SSI), and digital Start/Stop

Page 22-29

Rugged/special duty rod-style

SYNCHRONOUS SERIAL INTERFACE (SSI)

Rugged/special-duty rod-style linear position sensors with Synchronous Serial Interface (SSI) offer high accuracy and the fast update times necessary for dynamic closed-loop motion control applications.

Features

- Position resolution to 1 μm
- Non-linearity of $\pm 30 \mu\text{m}$
- Synchronous or asynchronous operation
- Binary and gray code versions

SSI

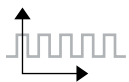

RUGGED/SPECIAL DUTY ROD-STYLE SYNCHRONOUS SERIAL INTERFACE (SSI) SPECIFICATIONS



Measured variable	Position
Measuring range	25...4000 mm
Available outputs	Synchronous Serial Interface (SSI) Binary or gray code, 24 bit, 25 bit
Non-linearity	$\pm 30 \mu\text{m}$ at $\leq 10 \mu\text{m}$ resolution or $\leq \pm 2$ LSB
Resolution	1, 2, 5, 10, 20, 40, 50, or 100 μm
Supply voltage	10...30 Vdc
Operating temperature	-40...+85 °C
Shock rating	100g/6 ms as per EN 60068-2-27
Vibration rating	12g, 10...2000 Hz as per EN60068-2-6
Operating pressure	600 bar (pressure tube portion)
Environmental rating	IP67 (connector versions) IP68 (integral cable versions)



HOW TO ORDER STYLE H AND W (THREAD-IN) AND STYLE K (BOLT-IN)

Ordering example: BTL5 - S1 - M - - -

Output format

- 0 Binary code rising (24-bit)
- 1 Gray code rising (24-bit)
- 6 Binary code rising (25-bit)
- 7 Gray code rising (25-bit)

Resolution

- 1 1 µm
- 2 5 µm
- 3 10 µm
- 4 20 µm
- 5 40 µm
- 6 100 µm
- 7 2 µm
- 8 50 µm

Synchronous / Asynchronous operation

- [blank] Asynchronous, output value at null point = 0
- B Synchronous, output value at null point = 0

Standard nominal stroke [mm]

0025...4000 in 1 mm increments

Design / Mounting threads

- K Bolt-in
10.2 mm Ø pressure tube
40 mm null point
- K8 Bolt-in
8 mm Ø pressure tube
40 mm null point
(max. stroke length = 1016 mm)
- W 3/4"-16 UNF thread-in
10.2 mm Ø pressure tube
50.8 mm (2") null point
- W8 3/4"-16 UNF thread-in
8 mm Ø pressure tube
50.8 mm (2") null point
(max. stroke length = 1016 mm)
- H M18x1.5 thread-in
10.2 mm Ø pressure tube
30 mm null point
- H8 M18x1.5 thread-in
8 mm Ø pressure tube
30 mm null point
(max. stroke length = 1016 mm)

Connection

- Radial output
- K02 PUR cable 2 m
 - K05 PUR cable 5 m
 - K10 PUR cable 10 m
 - K15 PUR cable 15 m
 - SR32 Connector
- Radial output
- K02 PUR cable 2 m
 - K05 PUR cable 5 m
 - K10 PUR cable 10 m
 - K15 PUR cable 15 m
- Axial output
- KA02 PUR cable 2 m
 - KA05 PUR cable 5 m
 - KA10 PUR cable 10 m
 - KA15 PUR cable 15 m
 - S32 Connector

HOW TO ORDER STYLE HB AND WB IP69K (THREAD-IN)

Ordering example: BTL5 - S1 - B - M - - - - C

Output format

- 0 Binary code rising (24-bit)
- 1 Gray code rising (24-bit)
- 2 Binary code falling (24-bit)
- 3 Gray code falling (24-bit)
- 6 Binary code rising (25-bit)
- 7 Gray code rising (25-bit)
- 8 Binary code falling (25-bit)
- 9 Gray code falling (25-bit)

Resolution

- 2 5 µm
- 3 10 µm
- 4 20 µm
- 5 40 µm
- 6 100 µm
- 7 2 µm
- 8 50 µm

Standard nominal stroke [mm]

0025...4000 in 1 mm increments

Design / Mounting threads

- HB M18x1.5 threads
- WB 3/4"-16 UNF threads

Connection

- FA05 PUR cable 2 m
- F05 PUR cable 5 m

Rugged/special duty rod-style

ANALOG INTERFACE

Balluff rugged rod-style linear position sensors with analog interface are ideal for use in hydraulic cylinder position monitoring applications in demanding environments.

Features

- Analog voltage or current versions available
- Field-scalable stroke length
- Stroke lengths to 7620 mm

ANALOG



RUGGED/SPECIAL DUTY ROD-STYLE ANALOG INTERFACE SPECIFICATIONS



Measured variable	Position
Measuring range	25...7620 mm
Available outputs	0...10 V/10...0 V, -10...10 V/10...-10 V, 0...20 mA, 4...20 mA
Non-linearity	±50 µm at ≤ 500 mm nominal stroke ±0.01% 501...5500 mm nominal stroke ±0.02% > 5500 mm nominal stroke
Resolution	System resolution/min. 2 µm
Supply voltage	10...30 Vdc
Operating temperature	-40...+85 °C
Shock rating	150g/6 ms as per EN 60068-2-27
Vibration rating	20g, 10...2000 Hz as per EN60068-2-6
Operating pressure	600 bar (pressure tube portion)
Environmental rating	IP67 (connector versions) IP68 (integral cable versions)



HOW TO ORDER STYLE H AND W (THREAD-IN) AND STYLE K (BOLT-IN)

Ordering example: **BTL7 - 5 0 - M** - - -

Output signal

- A 0...10 V and 10...0 V
- G -10...10 V and 10...-10 V
- E 4...20 mA or 20...4 mA
- C 0...20 mA or 20...0 mA

Output signal characteristic

- 1 Rising and falling (output types A and G)
- 0 Rising (output types C and E)
- 7 Falling (output types C and E)

Standard nominal stroke [mm]

0025...7620 in 1 mm increments

Design / Mounting threads

- K Bolt-in
8 mm Ø pressure tube
40 mm null point
- K8 Bolt-in
8 mm Ø pressure tube
40 mm null point
(max. stroke length = 1016 mm)
- W 3/4"-16 UNF thread-in
10.2 mm Ø pressure tube
50.8 mm (2") null point
- W8 3/4"-16 UNF thread-in
8 mm Ø pressure tube
50.8 mm (2") null point
(max. stroke length = 1016 mm)
- H M18x1.5 thread-in
10.2 mm Ø pressure tube
30 mm null point
- H8 M18x1.5 thread-in
8 mm Ø pressure tube
30 mm null point
(max. stroke length = 1016 mm)

Connection

- Radial output
 - K02 PUR cable 2 m
 - K05 PUR cable 5 m
 - K10 PUR cable 10 m
 - K15 PUR cable 15 m
 - SR32 Connector
- Radial output
 - K02 PUR cable 2 m
 - K05 PUR cable 5 m
 - K10 PUR cable 10 m
 - K15 PUR cable 15 m
- Axial output
 - KA02 PUR cable 2 m
 - KA05 PUR cable 5 m
 - KA10 PUR cable 10 m
 - KA15 PUR cable 15 m
 - S32 Connector

HOW TO ORDER STYLE HB AND WB IP69K (THREAD-IN)

Ordering example: **BTL7 - 5 0 - M** - - -

Output signal

- A 0...10 V
- G -10...10 V
- E 4...20 mA
- C 0...20 mA

Output signal characteristic

- 1 Rising and falling (output types A and G)
- 0 Rising (output types C and E)
- 7 Falling (output types C and E)

Design / Mounting threads

- HB M18x1.5 thread-in,
O-ring, rod diameter 10.2 mm
- WB 3/4"-16 UNF thread-in,
O-ring, rod diameter 10.2 mm

Standard nominal stroke [mm]

0025...7620 in 1 mm increments

Connection

- Radial output
 - K05 PUR cable 5 m
 - F05 PTFE cable 5 m
- Axial output
 - KA05 PUR cable 5 m
 - FA05 PTFE cable 5 m

Rugged/special duty rod-style

DIGITAL PULSE INTERFACE

Balluff linear position sensors with digital Start/Stop interfaces allow simple connection to control systems with compatible Start/Stop interface hardware. The RS-485 differential signal provides excellent noise immunity and allows sensor-to-controller cable lengths up to 500 meters.

Features

- Noise immune RS-485 signal transmission
- Stroke lengths to 7620 mm
- Position resolution to 1 μm (controller dependent)





RUGGED/SPECIAL DUTY ROD-STYLE
DIGITAL PULSE INTERFACE SPECIFICATIONS



Measured variable	Position
Measuring range	25...5080 mm
Available outputs	RS485 Start/Stop pulse interface
Non-linearity	$\pm 100 \mu\text{m}$ at ≤ 500 mm nominal stroke $\pm 0.02\%$ > 500 mm nominal stroke
Resolution	$\leq 2 \mu\text{m}$ (controller dependent)
Supply voltage	20...28 Vdc
Operating temperature	-40...+85 °C
Shock rating	100g/6 ms as per EN 60068-2-27
Vibration rating	12g, 10...2000 Hz as per EN60068-2-6
Operating pressure	600 bar (pressure tube portion)
Environmental rating	IP67 (connector versions) IP68 (integral cable versions)



HOW TO ORDER STYLE H AND W (THREAD-IN) AND STYLE K (BOLT-IN)

Ordering example: **BTL5 - P1 - M**  -  - 

Standard nominal stroke [mm]
0025...5080 in 1 mm increments



Design / Mounting threads

- K** Bolt-in
10.2 mm Ø pressure tube
40 mm null point
- K8** Bolt-in
8 mm Ø pressure tube
40 mm null point
(max. stroke length = 1016 mm)
- W** 3/4"-16 UNF thread-in
10.2 mm Ø pressure tube
50.8 mm (2") null point
- W8** 3/4"-16 UNF thread-in
8 mm Ø pressure tube
50.8 mm (2") null point
(max. stroke length = 1016 mm)
- H** M18x1.5 thread-in
10.2 mm Ø pressure tube
30 mm null point
- H8** M18x1.5 thread-in
8 mm Ø pressure tube
30 mm null point
(max. stroke length = 1016 mm)

Connection

- Radial output
 - K02 PUR cable 2 m
 - K05 PUR cable 5 m
 - K10 PUR cable 10 m
 - K15 PUR cable 15 m
 - SR32 Connector
- Radial output
 - K02 PUR cable 2 m
 - K05 PUR cable 5 m
 - K10 PUR cable 10 m
 - K15 PUR cable 15 m
- Axial output
 - KA02 PUR cable 2 m
 - KA05 PUR cable 5 m
 - KA10 PUR cable 10 m
 - KA15 PUR cable 15 m
 - S32 Connector

HOW TO ORDER STYLE HB AND WB IP69K (THREAD-IN)

Ordering example: **BTL5 - P1 - M**  -  -  - **C**

Standard nominal stroke [mm]
0025...5080 in 1 mm increments

Design / Mounting threads

- HB** M18x1.5 thread-in
- WB** 3/4"-16 UNF thread-in

Connection

- Radial output
 - F05 PTFE cable 5 m
- Axial output
 - FA05 PTFE cable 5 m

Hazardous area rod-style

Rod-style linear position sensors for use in hazardous locations

Balluff hazardous area rod-style linear position sensors are designed, tested, and approved for use in areas with potentially explosive gases or dust. Depending on the version, these sensors can be used in a variety of hazardous applications around the globe.

Features

- Worldwide certifications (version dependent)
- ATEX, IECEx, and North American approvals (version dependent)
- Multiple versions to meet varying application requirements
- Some versions offer field-replaceable internal electronics allowing simple, fast field repairs in uptime-critical applications



EX-PROOF ROD-STYLE – BOLT-IN

Featuring a rugged and robust stainless steel housing, extremely rugged bolt-in mounting, and full worldwide hazardous location approvals

Features

- North American (NEC, CSA), ATEX, and IECEx approvals
- Approved for Class I, Div 1 / zones 0, 1, and 2
- Stroke lengths to 7620 mm
- Available interfaces include analog, Synchronous Serial Interface, and digital Start/Stop
- Field-replaceable sensing cartridge minimizes downtime

Page 32-37



EX-PROOF ROD-STYLE – THREAD-IN

Compact, robust stainless steel housing and thread-in design can be installed in place of a standard rod-style sensor in locations with potentially hazardous gases or dusts.

Features

- ATEX and IECEx approvals
- Available interfaces include analog, Synchronous Serial Interface, and digital Start/Stop
- Stroke lengths to 7620 mm (interface dependent)

Page 28-43



INCREASED SAFETY ROD-STYLE – THREAD-IN

Standard in-cylinder rod-style position sensor rated for use in Zone 2 / Class I, Div 2 areas

Features

- North American (NEC, CSA), ATEX, and IECEx approvals
- Analog interface
- Stroke lengths to 5500 mm

Page 44-49

Bolt-in ex-proof TA12

ANALOG INTERFACE

Balluff TA12 ex-proof linear position sensors with analog interface are ideal for use in position monitoring applications in areas with potentially explosive gases or dust.

Features

- Analog voltage or current versions available
- Field-scalable stroke length
- Stroke lengths to 7620 mm

ANALOG



BOLT-IN EX-PROOF TA12 ANALOG INTERFACE SPECIFICATIONS

Measured variable	Position
Measuring range	25...7620 mm
Available outputs	0...10 V/10...0 V, -10...10 V/10...-10 V, 0...20 mA, 4...20 mA
Non-linearity	±50 µm at ≤ 500 mm nominal stroke ±0.01% 501...5500 mm nominal stroke ±0.02% > 5500 mm nominal stroke
Resolution	System resolution/min. 2 µm
Supply voltage	10...30 Vdc
Operating temperature	-40...+85 °C
Shock rating	150g/6 ms as per EN 60068-2-27
Vibration rating	20g, 10...2000 Hz as per EN60068-2-6
Operating pressure	600 bar (pressure tube portion)
Environmental rating	IP67 (connector versions) IP68 (integral cable versions)
Approvals	ATEX, IECEx, CSA (US and Canada)



APPROVALS



Class I Zone 1 AEx d IIC T* Ga/Gb T6 Ta -50° to 70°C, T5 Ta -50° to 80°C
 Class I Zone 1 Ex d IIC T* Gb T6 Ta -50° to 70°C, T5 Ta -50° to 80°C
 Class I, Division 1, Groups A,B,C,D
 Class II, Division 1, Groups E,F,G;
 Class III T6 Ta -50° to 70°C, T5 Ta -50° to 80°C Type 4X/6P; IP68
 SIRA 11ATEX1104X
 IECEx SIR 11.0048X



Ex II 1/2GD
 Ex d IIC T* Ga/Gb Ta -50° to 70°C (T6) -50° to 80°C (T5)
 Ex t IIIC T85/T100°C Da IP68 Ta -50° to 70°C (T85) -50° to 80°C (T100)
 CE 0518 Ex (manufactured in the USA)
 CE 0102 Ex (manufactured in Germany and Hungary)

HOW TO ORDER STANDARD VERSION

Ordering example: **BTL7 - 5 - M - J - DEXC - TA 12**

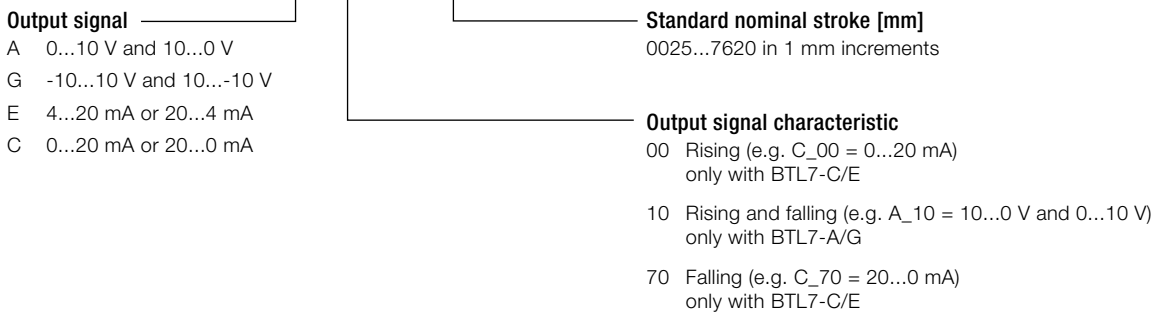

HOW TO ORDER USB CONFIGURABLE VERSION

Ordering example: **BTL7 - 501 - M - J - DEXC - TA 12**

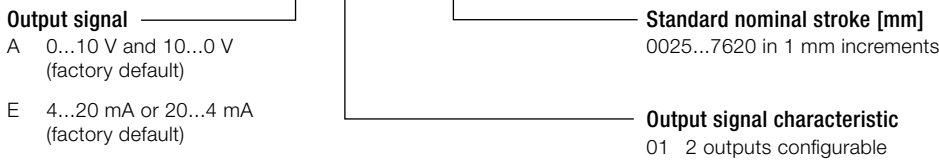

Bolt-in ex-proof TA12

SYNCHRONOUS SERIAL INTERFACE (SSI)

Balluff linear position sensors with Synchronous Serial Interface (SSI) offer high accuracy and the fast update times necessary for superior dynamic motion control applications.

SSI linear position sensors are available in both standard and USB configurable versions. The standard version offers 100% backward compatibility to legacy SSI linear position sensors, while the USB configurable version offers advanced user-configuration options via the PC-based configuration tool. Both versions offer position resolution down to 1 μm , and stroke lengths to 7620 mm (300 inches).

Features

- Position resolution to 1 μm
- Non-linearity of $\pm 30 \mu\text{m}$
- Synchronous or asynchronous operation
- Binary and gray code versions

SSI



BOLT-IN EX-PROOF TA12 SYNCHRONOUS SERIAL INTERFACE (SSI) SPECIFICATIONS

Measured variable	Position (standard version) Position and velocity (USB configurable version)
Measuring range	25...7620 mm
Available outputs	Synchronous Serial Interface (SSI) Binary or gray code, 24 bit, 25 bit, 26 bit
Non-linearity	$\pm 30 \mu\text{m}$ with 5 and 10 μm resolution or $\leq \pm 2 \text{ LSB}$
Resolution	1, 2, 5, 10, 20, 40, 50, or 100 μm
Supply voltage	10...30 Vdc
Operating temperature	-40...+85 °C
Shock rating	150g/6 ms as per EN 60068-2-27
Vibration rating	20g, 10...2000 Hz as per EN60068-2-6
Operating pressure	600 bar (pressure tube portion)
Environmental rating	IP67 (connector versions) IP68 (integral cable versions)
Approvals	ATEX, IECEx, CSA (US and Canada)



APPROVALS



Class I Zone 1 AEx d IIC T* Ga/Gb T6 Ta -50° to 70°C, T5 Ta -50° to 80°C
 Class I Zone 1 Ex d IIC T* Gb T6 Ta -50° to 70°C, T5 Ta -50° to 80°C
 Class I, Division 1, Groups A,B,C,D
 Class II, Division 1, Groups E,F,G;
 Class III T6 Ta -50° to 70°C, T5 Ta -50° to 80°C Type 4X/6P; IP68
 SIRA 11ATEX1104X
 IECEx SIR 11.0048X



Ex II 1/2GD
 Ex d IIC T* Ga/Gb Ta -50° to 70°C (T6) -50° to 80°C (T5)
 Ex t IIIC T85/T100°C Da IP68 Ta -50° to 70°C (T85) -50° to 80°C (T100)
 CE 0518 Ex (manufactured in the USA)
 CE 0102 Ex (manufactured in Germany and Hungary)

HOW TO ORDER STANDARD VERSION

Ordering example: **BTL7-S5** **-M** **-J-DEXC-TA12**

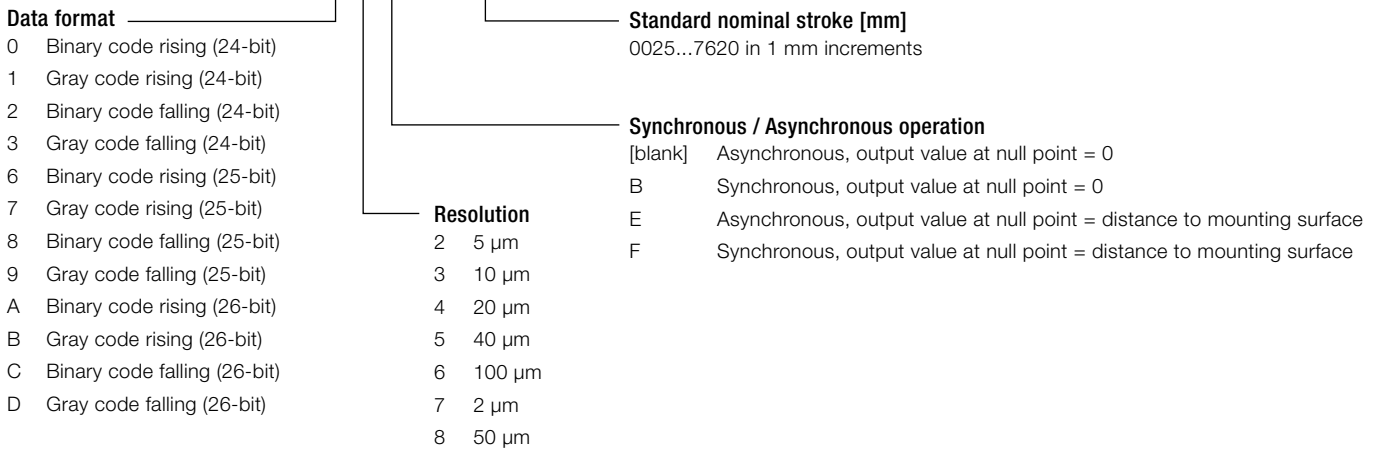

HOW TO ORDER USB CONFIGURABLE VERSION

Ordering example: **BTL7-S510** **-M** **-J-DEXC-TA12**

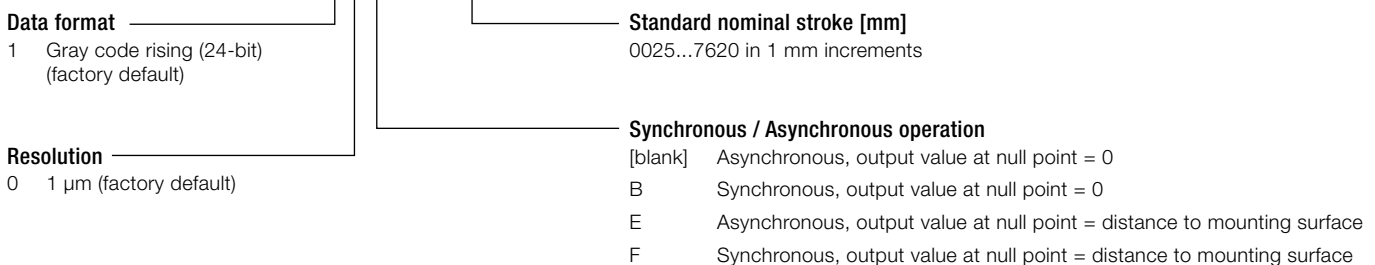

Bolt-in ex-proof TA12

DIGITAL PULSE INTERFACE

Balluff linear position sensors with digital Start/Stop interfaces allow simple connection to control systems with compatible Start/Stop interface hardware. The RS-485 differential signal provides excellent noise immunity, and allows sensor-to-controller cable lengths up to 500 meters.

Features

- Position resolution to 1 μm
- Non-linearity of $\pm 30 \mu\text{m}$
- Synchronous or asynchronous operation
- Binary and gray code versions

DIGITAL PULSE



BOLT-IN EX-PROOF TA12 DIGITAL PULSE INTERFACE SPECIFICATIONS

Measured variable	Position
Measuring range	25...7620 mm
Available outputs	DPI/IP Start/Stop Pulse Interface
Non-linearity	$\pm 50 \mu\text{m}$ at ≤ 500 mm nominal stroke $\pm 0.01\%$ 501...5500 mm nominal stroke $\pm 0.02\%$ > 5500 mm nominal stroke
Resolution	1 μm
Supply voltage	10...30 Vdc
Operating temperature	-40...+85 °C
Shock rating	150g/6 ms as per EN 60068-2-27
Vibration rating	20g, 10...2000 Hz as per EN60068-2-6
Operating pressure	600 bar (pressure tube portion)
Environmental rating	IP67 (connector versions) IP68 (integral cable versions)
Approvals	ATEX, IECEx, CSA (US and Canada)



APPROVALS



Class I Zone 1 AEx d IIC T* Ga/Gb T6 Ta -50° to 70°C, T5 Ta -50° to 80°C
 Class I Zone 1 Ex d IIC T* Gb T6 Ta -50° to 70°C, T5 Ta -50° to 80°C
 Class I, Division 1, Groups A,B,C,D
 Class II, Division 1, Groups E,F,G;
 Class III T6 Ta -50° to 70°C, T5 Ta -50° to 80°C Type 4X/6P; IP68
 SIRA 11ATEX1104X
 IECEX SIR 11.0048X



Ex II 1/2GD
 Ex d IIC T* Ga/Gb Ta -50° to 70°C (T6) -50° to 80°C (T5)
 Ex t IIC T85/T100°C Da IP68 Ta -50° to 70°C (T85) -50° to 80°C (T100)
 CE 0518 Ex (manufactured in the USA)
 CE 0102 Ex (manufactured in Germany and Hungary)

HOW TO ORDER

Ordering example: **BTL7 - P511 - M** **- J - DEXC - TA12**

Standard nominal stroke [mm]
 0025...7620 in 1 mm increments

Thread-in ex-proof

ANALOG INTERFACE

Balluff ex-proof rod-style linear position sensors with analog interface are the ideal choice for hydraulic cylinder position monitoring applications across a variety of markets and industries.

Features

- Analog voltage or current versions available
- Field-scalable stroke length
- Stroke lengths to 7620 mm

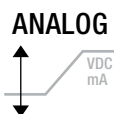

THREAD-IN EX-PROOF ANALOG INTERFACE SPECIFICATIONS



Measured variable	Position
Measuring range	25...7620 mm
Available outputs	0...10 V/10...0 V, -10...10 V/10...-10 V, 0...20 mA, 4...20 mA
Non-linearity	±50 µm at ≤ 500 mm nominal stroke ±0.01% 501...5500 mm nominal stroke ±0.02% > 5500 mm nominal stroke
Resolution	System resolution/min. 2 µm
Supply voltage	10...30 Vdc
Operating temperature	-40...+85 °C
Shock rating	150g/6 ms as per EN 60068-2-27
Vibration rating	20g, 10...2000 Hz as per EN60068-2-6
Operating pressure	600 bar (pressure tube portion)
Environmental rating	IP67 (connector versions) IP68 (integral cable versions)
Approvals	ATEX, IECEx



APPROVALS

- II 1/2 G Ex d IIC T6/T5 Ga/Gb Ta +65°C (T6) +80°C (T5) X for gases and
 II 2 D Ex tb IIIC T85°C/T100°C Db IP67 Ta +65°C (T85) +80°C (T100) X for flammable dust (only zone 21) fulfills the requirements for electrical equipment for explosive areas in accordance with the following standards:
- EN 60079-0: General requirements
 - EN 60079-1: Ignition protection "d"
 - EN 60079-26: Equipment with equipment protection level (EPL) Ga
 - EN 60079-31: Ignition protection "t"

Compliance is proven through the EC type examination certificate EPS 13 ATEX 1 576 X and a CE declaration of conformity.



The transducer is certified under certificate number IECEx EPS 13.0024X. The current version can be found under www.iecex.com



RU C-DE.MIO62.B.03686

Ex d IIC T6 Ga/Gb
Ex tb IIIC T85°C Db IP67
-40°C ≤ Ta ≤ +65°C

Ex d IIC T5 Ga/Gb
Ex tb IIIC T100°C Db IP67
-40°C ≤ Ta ≤ +80°C

HOW TO ORDER

Ordering example: **BTL7 - 5 - M - - DEX -**

Output signal

- A 0...10 V
- G -10...10 V
- E 4...20 mA
- C 0...20 mA

Output signal characteristic

- 00 Rising (e.g. C_00 = 0...20 mA) only with BTL7-C/E
- 10 Rising and falling (e.g. A_10 = 10...0 V and 0...10 V) only with BTL7-A/G
- 70 Falling (e.g. C_70 = 20...0 mA) only with BTL7-C/E

Connection

- K05 Cable 5 m (radical)
- KA05 Cable 5 m (axial)

Rod end

- A Float stop
- B Short end

Rod version, fastening

- B Metric thread M18x1.5
- Z Inch thread 3/4"-16 UNF

Standard nominal stroke [mm]

0025...7620 in 1 mm increments

Note: The products shown on this page is approved for use in applications covered by ATEX or IECEx guidelines. These products are not approved for use under North American NEC guidelines. These products are available for sale in North America, but only for use on equipment that is to be exported into a country or region for which the ATEX and/or IECEx guidelines are applicable.

It is the responsibility of the user to ensure that the product carries the appropriate approvals for the area in which it will be used.

Thread-in ex-proof

SYNCHRONOUS SERIAL INTERFACE (SSI)

Balluff ex-proof linear position sensors with Synchronous Serial Interface (SSI) offer high accuracy and the fast update times necessary for demanding closed-loop motion control applications.

Features

- Position resolution to 1 μm
- Non-linearity of $\pm 30 \mu\text{m}$
- Synchronous or asynchronous operation
- Binary and gray code versions

SSI

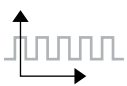

THREAD-IN EX-PROOF
SYNCHRONOUS SERIAL INTERFACE (SSI)
SPECIFICATIONS



Measured variable	Position
Measuring range	25...4000 mm
Available outputs	Synchronous Serial Interface (SSI) Binary or Gray code, 24 bit, 25 bit
Non-linearity	$\pm 30 \mu\text{m}$ at $\leq 10 \mu\text{m}$ resolution or $\leq \pm 2$ LSB
Resolution	1,2,5,10,20,40,50, or 100 μm
Supply voltage	20...28 Vdc
Operating temperature	-40...+85 °C
Shock rating	100g/6 ms as per EN 60068-2-27
Vibration rating	12g, 10...2000 Hz as per EN60068-2-6
Operating pressure	600 bar (pressure tube portion)
Environmental rating	IP67 (connector versions) IP68 (integral cable versions)
Approvals	ATEX, IECEx



APPROVALS



Ex: II 1/2 G
Ex D IIB+H₂T6



IECEX: Ex d IIB+H₂ T6 Ga/Gb

CSA/NEC: None

HOW TO ORDER

Ordering example: **BTL5-S1** - **M** - **DEX** -

Data format

- 0 Binary code rising (24-bit)
- 1 Gray code rising (24-bit)
- 2 Binary code falling (24-bit)
- 3 Gray code falling (24-bit)
- 6 Binary code rising (25-bit)
- 7 Gray code rising (25-bit)
- 8 Binary code falling (25-bit)
- 9 Gray code falling (25-bit)

Resolution

- 2 5 µm
- 3 10 µm
- 4 20 µm
- 5 40 µm
- 8 50 µm

Connection

- K05 Cable 5 m (radical)
- KA05 Cable 5 m (axial)

Rod end

- A Float stop
- B Short end

Rod version, fastening

- B Metric thread M18x1.5
- Z Inch thread 3/4"-16 UNF

Standard nominal stroke [mm]

0025...4000 in 1 mm increments

Note: The products shown on this page is approved for use in applications covered by ATEX or IECEx guidelines. These products are not approved for use under North American NEC guidelines. These products are available for sale in North America, but only for use on equipment that is to be exported into a country or region for which the ATEX and/or IECEx guidelines are applicable.

It is the responsibility of the user to ensure that the product carries the appropriate approvals for the area in which it will be used.

Thread-in ex-proof

DIGITAL PULSE INTERFACE

Balluff ex-proof linear position sensors with digital Start/Stop interfaces allow simple connection to control systems with compatible Start/Stop interface hardware. The RS-485 differential signal provides excellent noise immunity and allows sensor-to-controller cable lengths up to 500 meters.

Features

- Noise immune RS-485 signal transmission
- Stroke lengths to 7620 mm
- Position resolution to 1 μm (controller dependent)

DIGITAL PULSE



THREAD-IN EX-PROOF DIGITAL PULSE INTERFACE SPECIFICATIONS



Measured variable	Position
Measuring range	25...5080 mm
Available outputs	RS485 Start/Stop pulse interface
Non-linearity	$\pm 100 \mu\text{m} \leq 500 \text{ mm nominal stroke}$ $\pm 0.02\% > 500 \text{ mm nominal stroke}$
Resolution	$\leq 2 \mu\text{m}$ (controller dependent)
Supply voltage	20...28 Vdc
Operating temperature	-40...+85 °C
Shock rating	100g/6 ms as per EN 60068-2-27
Vibration rating	12g, 10...2000 Hz as per EN60068-2-6
Operating pressure	600 bar (pressure tube portion)
Environmental rating	IP67 (connector versions) IP68 (integral cable versions)
Approvals	ATEX, IECEx



APPROVALS



Ex: II 1/2 G
Ex D IIB+H₂ T6



IECEx: Ex d IIB+H₂ T6 Ga/Gb

CSA/NEC: None

HOW TO ORDER

Ordering example: **BTL5 - P1 - M**  **-**  **- DEX** **-** 

Connection

- K05 Cable 5 m (radical)
- KA05 Cable 5 m (axial)

Rod end

- A Float stop
- B Short end

Rod version, fastening

- B Metric thread M18x1.5
- Z Inch thread 3/4"-16 UNF

Standard nominal stroke [mm]

0025...5080 in 1 mm increments

Note: The products shown on this page is approved for use in applications covered by ATEX or IECEx guidelines. These products are not approved for use under North American NEC guidelines. These products are available for sale in North America, but only for use on equipment that is to be exported into a country or region for which the ATEX and/or IECEx guidelines are applicable.

It is the responsibility of the user to ensure that the product carries the appropriate approvals for the area in which it will be used.

ATEX / IECEx increased safety (NEX)

ANALOG INTERFACE

Balluff NEX rod-style linear position transducers are intended for use in areas where explosive gases and dusts could be present but are not normally present.

Offering the same functionality as standard in-cylinder rod-style versions, the NEX versions provide additional ATEX, IECEx, and CSA approval for use in potentially hazardous areas around the world.

Features

- Analog voltage or current versions available
- Field-scalable stroke length via included push-button teach tool (standard version)
- Advanced field set-up, scaling, and configuration (USB configurable version)
- Integrated status LEDs for condition monitoring and diagnostics
- Stroke lengths to 5500 mm

ANALOG



ATEX / IECEx INCREASED SAFETY (NEX) ANALOG INTERFACE SPECIFICATIONS



Measured variable	Position (standard version) Position and velocity (USB-configurable version)
Measuring range	25...5500 mm
Available outputs	0...10 V/10...0 V, -10...10 V/10...-10 V, 0...20 mA, 4...20 mA
Non-linearity	±50 µm at ≤ 500 mm nominal stroke ±0.01% 501...5500 mm nominal stroke ±0.02% > 5500 mm nominal stroke
Resolution	System resolution/min. 2 µm
Supply voltage	10...30 Vdc
Operating temperature	-40...+60 °C
Shock rating	150g/6 ms as per EN 60068-2-27
Vibration rating	20g, 10...2000 Hz as per EN60068-2-6
Operating pressure	600 bar (pressure tube portion)
Environmental rating	IP67 (connector versions) IP68 (integral cable versions)
Approvals	ATEX, IECEx, CSA (US and Canada)



APPROVALS



ATEX
 II 3 G Ex nA IIC T4 Gc
 II 2 D Ex tb IIIC T135°C Db IP 6x

IECEX
 Ex nA IIC T4 Gc
 Ex tb IIIC T135°C Db IP6x



U.S.
 Zone 2, AEx nA IIC Gc T4
 AEx tb IIIC Db T135°C

Canada
 Class I, Zone 2, Ex nA IIC T4
 Ex tb IIIC T135°C

NI (non-incendive)
 Class I, Division 2, Groups ABCD
 Class II, Division 2, Groups EFG; T4

HOW TO ORDER STANDARD VERSION

Ordering example: **BTL7 - [] - M [] - [] - NEX - []**

Output signal

- A 0...10 V
- G -10...10 V
- C 0...20 mA
- E 4...20 mA

Supply voltage

- 1 20...28 V DC
- 5 10...30 V DC

Output signal characteristic

- 00 Rising (e.g. C_00 = 0...20 mA) only with BTL7-C/E
- 10 Rising and falling (e.g. A_10 = 10...0 V and 0...10 V) only with BTL7-A/G
- 70 Falling (e.g. C_70 = 20...0 mA) only with BTL7-C/E

Connection

- S32 8-pin, M16 plug per IEC 130-9
- KA05 Cable 5 m

Rod version, fastening

- A Metric mounting thread M18x1.5, O-ring, rod diameter 10.2 mm
- B Metric mounting thread M18x1.5, O-ring, rod diameter 10.2 mm
- Y 3/4"-16 UNF thread, O-ring, rod diameter 10.2 mm
- Z 3/4"-16 UNF thread, O-ring, rod diameter 10.2 mm
- A8 Metric mounting thread M18x1.5, O-ring, rod diameter 8 mm
- B8 Metric mounting thread M18x1.5, O-ring, rod diameter 8 mm
- Y8 3/4"-16 UNF thread, O-ring, rod diameter 8 mm
- Z8 3/4"-16 UNF thread, O-ring, rod diameter 8 mm

Standard nominal stroke [mm]

0025...5500 in 1 mm increments

HOW TO ORDER USB CONFIGURABLE VERSION

Ordering example: **BTL7 - [] 501 - M [] - [] - NEX - []**

Output signal

- A 0...10 V
- E 4...20 mA

Supply voltage

- 5 10...30 V DC

Output signal characteristic

- 01 2 outputs, configurable

Standard nominal stroke [mm]

0025...5500 in 1 mm increments

Connection

- S32 8-pin, M16 plug per IEC 130-9
- KA05 Cable 5 m

Rod version, fastening

- A Metric mounting thread M18x1.5, O-ring, rod diameter 10.2 mm
- B Metric mounting thread M18x1.5, O-ring, rod diameter 10.2 mm
- Y 3/4"-16 UNF thread, O-ring, rod diameter 10.2 mm
- Z 3/4"-16 UNF thread, O-ring, rod diameter 10.2 mm
- A8 Metric mounting thread M18x1.5, O-ring, rod diameter 8 mm
- B8 Metric mounting thread M18x1.5, O-ring, rod diameter 8 mm
- Y8 3/4"-16 UNF thread, O-ring, rod diameter 8 mm
- Z8 3/4"-16 UNF thread, O-ring, rod diameter 8 mm

ATEX / IECEx increased safety (NEX)

SYNCHRONOUS SERIAL INTERFACE (SSI)

Balluff NEX rod-style linear position transducers are intended for use in areas where explosive gases and dusts could be present but are not normally present.

Offering the same functionality as standard in-cylinder rod-style versions, the NEX versions provide additional ATEX, IECEx, and CSA approval for use in potentially hazardous areas around the world.

Features

- Position resolution to 1 μm
- Non-linearity of $\pm 30 \mu\text{m}$
- Synchronous or asynchronous operation
- Binary and gray code versions

SSI

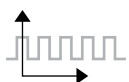

ATEX / IECEx INCREASED SAFETY (NEX) SYNCHRONOUS SERIAL INTERFACE (SSI) SPECIFICATIONS



Measured variable	Position (standard version) Position and velocity (USB configurable version)
Measuring range	25...5500 mm
Available outputs	Synchronous Serial Interface (SSI) Binary or Gray code, 24 bit, 25 bit, 26 bit
Non-linearity	$\pm 30 \mu\text{m}$ with 5 and 10 μm resolution or $\leq \pm 2 \text{ LSB}$
Resolution	1, 2, 5, 10, 20, 40, 50, or 100 μm
Supply voltage	10...30 Vdc
Operating temperature	-40...+85 °C
Shock rating	150g/6 ms as per EN 60068-2-27
Vibration rating	20g, 10...2000 Hz as per EN60068-2-6
Operating pressure	600 bar (pressure tube portion)
Environmental rating	IP67 (connector versions) IP68 (integral cable versions)
Approvals	ATEX, IECEx, CSA (US and Canada)



APPROVALS



ATEX
II 3 G Ex nA IIC T4 Gc
II 2 D Ex tb IIIC T135°C Db IP 6x

IECEX
Ex nA IIC T4 Gc
Ex tb IIIC T135°C Db IP6x



U.S.
Zone 2, AEx nA IIC Gc T4
AEx tb IIIC Db T135°C

Canada
Class I, Zone 2, Ex nA IIC T4
Ex tb IIIC T135°C

NI (non-incendive)
Class I, Division 2, Groups ABCD
Class II, Division 2, Groups EFG; T4

HOW TO ORDER STANDARD VERSION

Ordering example: **BTL7-S5** **-M** **-NEX-**

Data format

- 0 Binary code rising (24-bit)
- 1 Gray code rising (24-bit)
- 2 Binary code falling (24-bit)
- 3 Gray code falling (24-bit)
- 6 Binary code rising (25-bit)
- 7 Gray code rising (25-bit)
- 8 Binary code falling (25-bit)
- 9 Gray code falling (25-bit)
- A Binary code rising (26-bit)
- B Gray code rising (26-bit)
- C Binary code falling (26-bit)
- D Gray code falling (26-bit)

Resolution

- 2 5 µm
- 3 10 µm
- 4 20 µm
- 5 40 µm
- 8 50 µm

Connection

- S32 8-pin, M16 plug per IEC 130-9
- KA05 Cable 5 m

Rod version, fastening

- A Metric mounting thread M18x1.5, O-ring, rod diameter 10.2 mm
- B Metric mounting thread M18x1.5, O-ring, rod diameter 10.2 mm
- Y 3/4"-16 UNF thread, O-ring, rod diameter 10.2 mm
- Z 3/4"-16 UNF thread, O-ring, rod diameter 10.2 mm
- A8 Metric mounting thread M18x1.5, O-ring, rod diameter 8 mm
- B8 Metric mounting thread M18x1.5, O-ring, rod diameter 8 mm
- Y8 3/4"-16 UNF thread, O-ring, rod diameter 8 mm
- Z8 3/4"-16 UNF thread, O-ring, rod diameter 8 mm

Standard nominal stroke [mm]

0025...5500 in 1 mm increments

Synchronous/ asynchronous operation

- B Synchronous operation
- [blank] Asynchronous operation

HOW TO ORDER USB CONFIGURABLE VERSION

Ordering example: **BTL7-S510** **-M** **-NEX-**

Data format

- 1 Gray code rising (24-bit)
(factory default)

Resolution

- 0 1 µm
(factory default)

Synchronous/ asynchronous operation

- B Synchronous operation
- [blank] Asynchronous operation

Standard nominal stroke [mm]

0025...5500 in 1 mm increments

Connection

- S32 8-pin, M16 plug per IEC 130-9
- KA05 Cable 5 m

Rod version, fastening

- A Metric mounting thread M18x1.5, O-ring, rod diameter 10.2 mm
- B Metric mounting thread M18x1.5, O-ring, rod diameter 10.2 mm
- Y 3/4"-16 UNF thread, O-ring, rod diameter 10.2 mm
- Z 3/4"-16 UNF thread, O-ring, rod diameter 10.2 mm
- A8 Metric mounting thread M18x1.5, O-ring, rod diameter 8 mm
- B8 Metric mounting thread M18x1.5, O-ring, rod diameter 8 mm
- Y8 3/4"-16 UNF thread, O-ring, rod diameter 8 mm
- Z8 3/4"-16 UNF thread, O-ring, rod diameter 8 mm

ATEX / IECEx increased safety (NEX)

DIGITAL PULSE INTERFACE

Balluff NEX rod-style linear position transducers are intended for use in areas where explosive gases and dusts could be present but are not normally present.

Offering the same functionality as standard in-cylinder rod-style versions, the NEX versions provide additional ATEX, IECEx, and CSA approval for use in potentially hazardous areas around the world.

Features

- Noise immune RS-485 signal transmission
- Stroke lengths to 7620 mm
- Position resolution to 1 μm (controller dependent)



ATEX / IECEx INCREASED SAFETY (NEX)
DIGITAL PULSE INTERFACE SPECIFICATIONS



Measured variable	Position
Measuring range	25...7620 mm
Available outputs	DPI/IP Start/Stop Pulse Interface
Non-linearity	$\pm 50 \mu\text{m} \leq 500 \text{ mm}$ nominal stroke $\pm 0.01\% \ 501 \dots 5500 \text{ mm}$ nominal stroke $\pm 0.02\% > 5500 \text{ mm}$ nominal stroke
Resolution	1 μm
Supply voltage	10...30 Vdc
Operating temperature	-40...+85 °C
Shock rating	150g/6 ms as per EN 60068-2-27
Vibration rating	20g, 10...2000 Hz as per EN60068-2-6
Operating pressure	600 bar (pressure tube portion)
Environmental rating	IP67 (connector versions) IP68 (integral cable versions)
Approvals	ATEX, IECEx, CSA (US and Canada)



APPROVALS

**ATEX**

II 3 G Ex nA IIC T4 Gc
II 2 D Ex tb IIIC T135°C Db IP 6x

IECEX

Ex nA IIC T4 Gc
Ex tb IIIC T135°C Db IP6x

**U.S.**

Zone 2, AEx nA IIC Gc T4
AEx tb IIIC Db T135°C



Canada

Class I, Zone 2, Ex nA IIC T4
Ex tb IIIC T135°C

NI (non-incendive)

Class I, Division 2, Groups ABCD
Class II, Division 2, Groups EFG; T4

HOW TO ORDER

Ordering example: **BTL7 - P 5 1 1 - M**  - **- NEX -** 

Connection

S32 8-pin, M16 plug per IEC 130-9
KA05 Cable 5 m

Rod version, fastening

A Metric mounting thread M18x1.5, O-ring, rod diameter 10.2 mm
B Metric mounting thread M18x1.5, O-ring, rod diameter 10.2 mm
Y 3/4"-16 UNF thread, O-ring, rod diameter 10.2 mm
Z 3/4"-16 UNF thread, O-ring, rod diameter 10.2 mm
A8 Metric mounting thread M18x1.5, O-ring, rod diameter 8 mm
B8 Metric mounting thread M18x1.5, O-ring, rod diameter 8 mm
Y8 3/4"-16 UNF thread, O-ring, rod diameter 8 mm
Z8 3/4"-16 UNF thread, O-ring, rod diameter 8 mm

Standard nominal stroke [mm]

0025...7620 in 1 mm increments

External-mount profile-style

Maximum versatility and ease of use

Balluff linear position transducers in the profile-style housing are a rugged, wear-free alternative to other linear feedback devices such as wear-prone potentiometers, expensive and fragile glass scales, and limited stroke LVDTs. Environmentally sealed to IP67 and utilizing either a sliding captive magnet or a free-floating magnet, the profile housing sensors provide highly accurate linear position feedback in demanding, harsh industrial applications.

At home in numerous areas of factory automation, external-mount, profile-style linear position sensors provide highly accurate linear position feedback in demanding applications at stroke lengths up to 7620 mm (300 inches).

Features

- Position resolution to 0.5 μm
- Measuring lengths up to 7620 mm
- Measures several positions and speeds at the same time
- Non-contact magnetostrictive measurement principle for wear-free operation and long service life
- Wide variety of electrical interface options including analog, digital pulse, IO-Link, Synchronous Serial Interface (SSI), and various industrial fieldbuses
- Three housing variants for flexible and fast installation depending on the space requirements and application
- Floating and captive magnet options



STANDARD PROFILE-STYLE (P)

Standard-height profile-style housing with free-floating or captive sliding magnet options

Features

- Stroke lengths to 7620 mm (300")
- Available interfaces include analog, Ethernet, Synchronous Serial Interface (SSI), and digital Start/Stop

Page 52-59



LOW PROFILE-STYLE (PF)

Reduce-height low-profile housing with free-floating or captive sliding magnet options

Features

- Stroke lengths to 4572 mm (180")
- Available interfaces include IO-Link and analog

Page 60-63



TUBULAR PROFILE-STYLE (AT)

Tubular aluminum housing offers versatile mounting options at an economical price point. Available in free-floating magnet option only.

Features

- Stroke lengths to 1524 mm (60") for analog versions, and up to 4012 mm (158") for digital Start/Stop versions
- Non-contact floating magnet and tubular form factor allows for versatile installation options

Page 64-67

Standard profile-style

ETHERNET INTERFACES

Uniform, simple wiring, continuous diagnostics and central parameter setting via the controller are among the benefits of this linear position sensor with Ethernet/IP interface. The magnetostrictive system with flexible magnet mode (FMM) allows you to work with up to 16 position magnets. Two values can be output for each magnet: position and velocity. The sensor even automatically adapts itself to the number of magnets. This makes it easy to use in applications where a varying number of magnets are used. The wide range of functions provides great flexibility in linear position measurement – for example in hydraulic cylinder control or level measurement.

Features

- Synchronous measurement value acquisition and data transmission with Ethernet/IP CIP sync
- Fast, precise absolute position and velocity measurement with 1 µm resolution
- Simple and time-saving startup thanks to defined parameter substitution and flexible application tailoring
- Non-contact and wear-free, insensitive to contamination



STANDARD PROFILE-STYLE ETHERNET INTERFACES SPECIFICATIONS

Measured variable	Position and velocity
Measuring range	25...7620 mm
Available interfaces	Ethernet/IP EtherCAT PROFINET
Non-linearity	$\pm 50 \mu\text{m} \leq 500 \text{ mm nominal stroke}$ $\pm 0.02\% > 5500 \text{ mm nominal stroke}$
Resolution	1 µm
Supply voltage	10...30 Vdc
Operating temperature	-40...+85 °C
Shock rating	150g/6 ms as per EN 60068-2-27
Vibration rating	20g, 10...2000 Hz as per EN60068-2-6
Environmental rating	IP67



HOW TO ORDER

Ordering example: **BTL7-V50** - **M** **---** - **P** - **C003**

Output signal characteristic

0 Configurable

Interface

T PROFINET RT

E EtherCAT

D Ethernet/IP

Connection

C003 8-pin, 1xM8 plug + 2 x M12 plug, D-coded

Design

P Profile housing

Standard nominal stroke [mm]

0025...7620 in 1 mm increments

Standard profile-style

ANALOG INTERFACE

The standard profile-style position sensor can operate in flexible magnet mode (FMM) with one or two magnets and automatically responds to them. The system determines both position values simultaneously and independently of each other and transmits them through two separate analog outputs. The software configuration tool allows you to field-configure the sensor to suit application requirements: configure outputs for position, differential position, or velocity. This versatile functionality offers you great flexibility for handling the widest range of applications, such as position measurement in automated size-change on packaging conveyors, stroke monitoring on presses and punches, as well as many other factory automation tasks.

Features

- High-precision machine positioning
- Multi-magnet mode for flexible use
- Set parameters using PC software
- Capture measurement values fast with up to 4 kHz sampling frequency
- Wear-free and insensitive to contamination thanks to non-contact operating principle

ANALOG



STANDARD PROFILE-STYLE ANALOG INTERFACE SPECIFICATIONS



Measured variable	Position and velocity
Measuring range	25...7620 mm
Available interfaces	0...10V/10...0V, -10...10V/10...-10V, 0...20 mA, 4...20 mA
Non-linearity	±50 µm ≤ 500 mm nominal stroke ±0.01% 501...5500 mm nominal stroke ±0.02% > 5500 mm nominal stroke
Resolution	System resolution/min. 2 µm
Supply voltage	10...30 Vdc
Operating temperature	-40...+85 °C
Shock rating	150g/6 ms as per EN 60068-2-27
Vibration rating	20g, 10...2000 Hz as per EN60068-2-6
Environmental rating	IIP67 (connector versions) IP68 (integral cable versions)



HOW TO ORDER

Ordering example: **BTL7 -** **501 - M** **- P -**

Output signal

- A 0...10 V and 10...0 V
(factory default)
- G -10...10 V and 10...-10 V
(factory default)
- C 0...20 mA or 20...0 mA
(factory default)
- E 4...20 mA or 20...4 mA
(factory default)

Supply voltage

- 5 10...30 V DC

Output signal characteristic

- 01 2 outputs, configurable

Connection

- S32 8-pin, M16 plug per IEC 130-9
- S115 8-pin, M12 plug
- KA05 Cable 5 m (PUR)

Design

- P Profile housing

Standard nominal stroke [mm]

- 0025...7620 in 1 mm increments

Standard profile-style

SYNCHRONOUS SERIAL INTERFACE (SSI)

The standard profile-style linear position sensor with Synchronous Serial Interface (SSI) provides high-performance feedback and is ideal for demanding, dynamic motion control applications. These include applications with closed-loop axes. Data acquisition in the transducer is synchronized with the external clock of the controller. This enables the controller to perform accurate speed calculations. These transducers feature rugged construction with a high protection rating, simple installation and a wear-free, highly precise measuring principle.

Features

- High-accuracy machine positioning with synchronous data transmission and 1µm resolution
- Fast, dynamic measuring with up to 4 kHz sampling rate
- Stroke lengths up to 7620 mm
- Non-contact and wear-free, insensitive to contamination
- Time-saving installation and startup

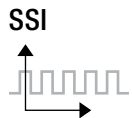

STANDARD PROFILE-STYLE SYNCHRONOUS SERIAL INTERFACE (SSI) SPECIFICATIONS



Measured variable	Position (standard version) Position and velocity (USB configurable version)
Measuring range	25...7620 mm
Available outputs	Synchronous Serial Interface (SSI) Binary or Gray code, 24 bit, 25 bit, 26 bit
Non-linearity	±30 µm with 5 and 10 µm resolution or $\leq \pm 2$ LSB
Resolution	1, 2, 5, 10, 20, 40, 50, or 100 µm
Supply voltage	10...30 Vdc
Operating temperature	-40...+85 °C
Shock rating	150g/6 ms as per EN 60068-2-27
Vibration rating	20g, 10...2000 Hz as per EN60068-2-6
Environmental rating	IP67 (connector versions) IP68 (integral cable versions)



HOW TO ORDER STANDARD VERSION

Ordering example: **BTL7 - S5** **- M** **- P -**

Data format

- 0 Binary code rising (24-bit)
- 1 Gray code rising (24-bit)
- 2 Binary code falling (24-bit)
- 3 Gray code falling (24-bit)
- 6 Binary code rising (25-bit)
- 7 Gray code rising (25-bit)
- 8 Binary code falling (25-bit)
- 9 Gray code falling (25-bit)
- A Binary code rising (26-bit)
- B Gray code rising (26-bit)
- C Binary code falling (26-bit)
- D Gray code falling (26-bit)

Resolution

- 1 1 µm
- 2 5 µm
- 3 10 µm
- 4 20 µm
- 5 40 µm
- 8 50 µm
- 9 0.5 µm

Connection

- S32 8-pin, M16 plug per IEC 130-9
- S115 8-pin, M12 plug
- S147 7-pin, M16 plug per DIN 45329
- KA05 Cable 5 m (PUR)
- FA05 Cable 5 m (PTFE)

Design

- P Profile housing

Standard nominal stroke [mm]

0025...7620 in 1 mm increments

Synchronous/ asynchronous operation

- B Synchronous operation
- [blank] Asynchronous operation

HOW TO ORDER USB CONFIGURABLE VERSION

Ordering example: **BTL7 - S510** **- M** **- P -**

Data format

- 1 Gray code rising (24-bit)
(factory default)

Resolution

- 0 1 µm
(factory default)

Connection

- S32 8-pin, M16 plug per IEC 130-9
- S115 8-pin, M12 plug
- KA05 Cable 5 m (PUR)
- FA05 Cable 5 m (PTFE)

Design

- P Profile housing

Standard nominal stroke [mm]

0025...7620 in 1 mm increments

Synchronous/ asynchronous operation

- B Synchronous operation
- [blank] Asynchronous operation

Standard profile-style

DIGITAL PULSE INTERFACE

Balluff linear position sensors with digital Start/Stop interfaces allow simple connection to control systems with compatible Start/Stop interface hardware. The RS-485 differential signal provides excellent noise immunity, and allows sensor-to-controller cable lengths up to 500 meters.

Features

- Noise immune RS-485 signal transmission
- Stroke lengths to 7620 mm
- Position resolution to 1 μm (controller dependent)



STANDARD PROFILE-STYLE DIGITAL PULSE INTERFACE SPECIFICATIONS



Measured variable	Position
Measuring range	25...7620 mm
Available outputs	DPI/IP Start/Stop Pulse Interface
Non-linearity	$\pm 30 \mu\text{m}$ with 5 and 10 μm resolution or $\leq \pm 2 \text{ LSB}$
Resolution	1, 2, 5, 10, 20, 40, 50, or 100 μm
Supply voltage	10...30 Vdc
Operating temperature	-40...+85 °C
Shock rating	150g/6 ms as per EN 60068-2-27
Vibration rating	20g, 10...2000 Hz as per EN60068-2-6
Environmental rating	IP67 (connector versions) IP68 (integral cable versions)



HOW TO ORDER STANDARD VERSION

Ordering example: **BTL7 - P 5 1 1 - M** **- P -**

Connection

- S32 8-pin, M16 plug per IEC 130-9
- S115 8-pin, M12 plug
- KA05 Cable 5 m (PUR)

Design

- P Profile housing

Standard nominal stroke [mm]

0025...7620 in 1 mm increments

Low profile-style

IO-LINK INTERFACE

The low profile PF linear position sensor provides accurate, reliable position feedback in a sleek, low-profile housing. Incorporating time-tested, field-proven non-contact magnetostrictive technology, the low profile PF linear position sensor offers an unmatched combination of performance, usability and value.

Features

- Precise machine positioning with 5 µm resolution
- Simultaneous position and speed measurement in one system
- Fast update time and data transmission with IO-Link
- Time-saving startup and flexible customizing with IO-Link
- Non-contact and wear-free, insensitive to contamination



LOW PROFILE-STYLE IO-LINK INTERFACE SPECIFICATIONS



Measured variable	Position and velocity
Measuring range	25...4572 mm
Available interfaces	IO-Link 1.1
Non-linearity	±200 µm ≤ 500 mm nominal stroke ±0.04% 501...4572 mm nominal stroke
Resolution	5 µm
Supply voltage	18...30 Vdc
Operating temperature	-25...+70 °C
Shock rating	100g/6 ms as per EN 60068-2-27
Vibration rating	12g, 10...2000 Hz as per EN60068-2-6
Environmental rating	IP67 (with connector attached)



HOW TO ORDER

Ordering example: **BTL6 - U110 - M**  **- PF - S4**

Standard nominal stroke [mm]
0025...4572 in 1 mm increments

Connection
S4 4-pin, M12 plug

Design
PF Flat profile housing

Low profile-style

ANALOG INTERFACE

The low profile PF linear position sensor provides accurate, reliable position feedback in a sleek, low-profile housing. Incorporating time-tested, field-proven non-contact magnetostrictive technology, the low profile PF linear position sensor offers an unmatched combination of performance, usability and value.

Features

- Field-scalable electrical stroke range
- Field-selectable output slope (increasing or decreasing)
- Rugged, low-profile housing
- Secure, compact 8-pin M12 connector
- Bi-color status LED
- Available with floating or captive position markers (magnets)

ANALOG



LOW PROFILE-STYLE ANALOG INTERFACE SPECIFICATIONS



Measured variable	Position
Measuring range	25...4572 mm
Available outputs	0...10V/10...0V, -10...10V/10...-10V, 0...20 mA, 4...20 mA
Non-linearity	±200 µm ≤ 500 mm nominal stroke ±0.04% 501...4572 mm nominal stroke
Resolution	≤ 0.35 mV (voltage output) ≤ 0.7 µA (current output)
Supply voltage	18...30 Vdc
Operating temperature	0...+70 °C
Shock rating	50g/6 ms as per EN 60068-2-27
Vibration rating	12g, 10...2000 Hz as per EN60068-2-6
Environmental rating	IP67 (with connector attached) IP68



HOW TO ORDER

Ordering example: **BTL6 - 500 - M - PF - S115**

Output signal

- A 0...10 V
- G -10...10 V
- C 0.1...20 mA
- E 4...20 mA

Connection

S115 8-pin, M12 plug

Design

PF Flat profile housing

Output signal characteristic

00 Rising (factory default, field-selectable)

Standard nominal stroke [mm]

0025...4572 in 1 mm increments

Tubular profile-style

ANALOG INTERFACE

The tubular profile-style linear position sensor with analog output is an economical alternative to less reliable position sensing products, such as resistive linear potentiometers. Field-proven, non-contact technology assures long service life and trouble-free operation.

Features

- Tubular housing offers flexible mounting options
- Compact, uniform profile allows the position magnet to move freely beyond the housing in overtravel situations
- Available outputs of 0...10V or -10...+10V
- Stroke lengths to 1524 mm (60")

ANALOG



TUBULAR PROFILE-STYLE ANALOG INTERFACE SPECIFICATIONS



Measured variable	Position
Measuring range	25...1524 mm
Available outputs	0...10V/10...0V, -10...10V/10...-10V
Non-linearity	$\pm 200 \mu\text{m} \leq 500 \text{ mm}$ nominal stroke $\pm 0.04\% \leq 1524 \text{ mm}$ nominal stroke
Resolution	Voltage output 0...10V: $\leq \pm 0.2 \text{ mV}$ or $10 \mu\text{m}$ Voltage output -10...10V: $\leq \pm 0.4 \text{ mV}$ or $10 \mu\text{m}$
Supply voltage	20...28 Vdc
Operating temperature	-25...+70 °C
Shock rating	50g/6 ms as per EN 60068-2-27
Vibration rating	12g, 10...2000 Hz as per EN60068-2-6
Environmental rating	IP67 (with connector attached)

HOW TO ORDER

Ordering example: **BTL 6 - - - M - A1 - S 115**

Output signal

A 0...10 V
G -10...10 V

Supply voltage

1 20...28 Vdc
3 20...28 Vdc (potential-isolated)

Connection

S115 8-pin, M12 plug

Design

A1 Profile housing, diameter 30 mm

Standard nominal stroke [mm]

0025...1524 in 1 mm increments

Output signal characteristics/Sampling rate

10 Rising and falling (e.g. A₋₁₀ = 10...0 V and 0...10 V)
sampling rate 1 kHz

11 Rising and falling (e.g. A₋₁₀ = 10...0 V and 0...10 V)
sampling rate 4 kHz at nominal length ≤ 275 mm, 2 kHz at nominal length ≤ 600 mm

STANDARD AVAILABLE STROKE LENGTHS*

Stroke Length (mm)	Inch Equivalent	Stroke Length (mm)	Inch Equivalent
0102	4	0560	22
0127	5	0610	24
0152	6	0661	26
0178	7	0711	28
0203	8	0762	30
0230	9	0813	32
0254	10	0914	36
0280	11	1016	40
0305	12	1067	42
0330	13	1220	48
0381	15	1270	50
0407	18	1372	54
0508	20	1524	60
0533	21		

*Additional stroke lengths available. Consult factory.

Tubular profile-style

DIGITAL PULSE INTERFACE

The tubular profile-style linear position sensor with digital pulse interface is an economical alternative to less reliable position sensing products, such as resistive linear potentiometers. Field-proven, non-contact technology assures long service life and trouble-free operation.

The start/stop digital pulse uses RS485 differential line drivers to provide excellent immunity to electrical interference, even at cable lengths up to 500 meters.

Features

- Tubular housing offers flexible mounting options
- Compact, uniform profile allows the position magnet to move freely beyond the housing in overtravel situations
- Multiple position magnets can be used, when supported by the controller
- Stroke lengths to 4012 mm (158")



TUBULAR PROFILE-STYLE
DIGITAL PULSE INTERFACE SPECIFICATIONS



Measured variable	Position
Measuring range	25...4012 mm
Available outputs	Start/Stop Pulse Interface
Non-linearity	$\pm 200 \mu\text{m} \leq 500 \text{ mm nominal stroke}$ $\pm 0.04\% 501 \dots 4012 \text{ mm nominal stroke}$
Resolution	10 μm
Supply voltage	20...28 Vdc
Operating temperature	0...+70 °C
Shock rating	50g/6 ms as per EN 60068-2-27
Vibration rating	12g, 10...2000 Hz as per EN60068-2-6
Environmental rating	IP67 (with connector attached)



HOW TO ORDER

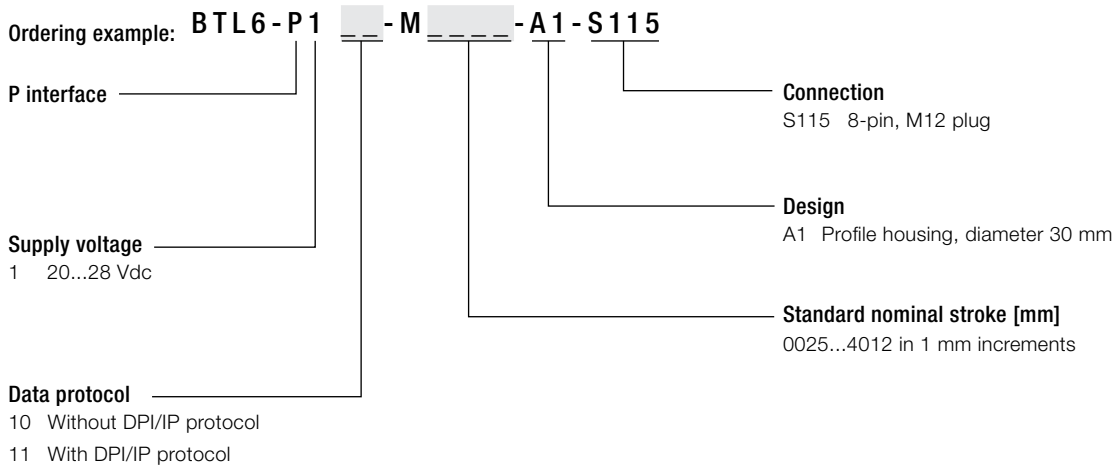

STANDARD AVAILABLE STROKE LENGTHS*

Stroke Length (mm)	Inch Equivalent	Stroke Length (mm)	Inch Equivalent
0051	2	0610	24
0077	3	0661	26
0102	4	0711	28
0127	5	0762	30
0152	6	0813	32
0178	7	0914	36
0203	8	1016	40
0230	9	1067	42
0254	10	1220	48
0280	11	1270	50
0305	12	1372	54
0330	13	1524	60
0381	15	1778	70
0407	18	2032	80
0508	20	2286	90
0533	21	2540	100
0560	22		

*Additional stroke lengths available. Consult factory.

Magnets, floats and cables

ACCESSORIES AND CONNECTIVITY

 *innovating automation*

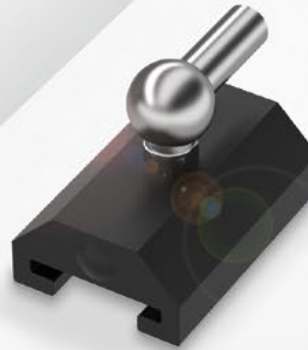



A wide variety of accessories for Balluff magnetostrictive linear position sensors are available to ensure maximum functionality, versatility and convenience.

Additional accessory options not shown here are available. Please consult the Balluff website for comprehensive cable, position magnet and mechanical accessory options.

Your Balluff solutions

- Position, captive and free-floating magnets
- Floats
- Cables

Accessories

POSITION MAGNETS AND FLOATS FOR ROD-STYLE SENSORS

POSITION MAGNETS



	BAM013L BTL-P-1013-4R	BAM013P BTL-P-1013-4S	BAM013R BTL-P-1014-2R
Description	Ring magnet	Slotted magnet	Ring magnet
Material	Aluminum	Aluminum	Aluminum
Dimension	Ø 32 x 8 mm	Ø 32 x 8 mm	Ø 21.9 x 8 mm
Inside diameter	13.0 mm	13.0 mm	13.5 mm

For additional magnet options, visit www.balluff.com

FLOATS



	BAM024J BTL2-S-3212-4Z	BAM0146 BTL2-S-4414-4Z	BAM0149 BTL2-S-5113-4K
Description	Barrel-shaped float	Barrel-shaped float	Spherical float
Material	Stainless steel (1.4404)	Stainless steel (1.4404)	Stainless steel (1.4404)
Dimension	Ø 32 x 53 mm	Ø 44 x 49 mm	Ø 50.9 x 52 mm
Inside diameter	11.7 mm	13.0 mm	13.0 mm

For additional float options, visit www.balluff.com

Accessories

POSITION MAGNETS FOR EXTERNAL MOUNT PROFILE-STYLE SENSORS

CAPTIVE MAGNETS



	BAM014H BTL5-F-2814-1S	BAM01FC BTL5-T-2814-1S
Description	Captive sliding magnet, top-exit swivel	Captive sliding magnet, front-exit swivel
Material	Iglidur J	Iglidur J
Dimension	28 x 29.9 x 40 mm	28 x 16.5 x 40 mm

For additional magnet options, visit www.balluff.com

CONTROL ARMS FOR CAPTIVE MAGNETS



	BAM000P BTL2-GS10-0100-A	BAM0003 BTL2-GS10-0300-A	BAM0006 BTL2-GS10-0500-A	BAM007J BTL2-GS10-1000-A
Description	Mechanical control arm, with swivel eye	Mechanical control arm, with swivel eye	Mechanical control arm, with swivel eye	Mechanical control arm, with swivel eye
Material	Aluminum Anodized	Aluminum Anodized	Aluminum Anodized	Aluminum Anodized
Dimension	Ø 10 x 100 mm	Ø 10 x 300 mm	Ø 10 x 500 mm	Ø 10 x 1000 mm

For control arms from 75mm to 2000 mm are available, visit www.balluff.com

FREE-FLOATING MAGNETS

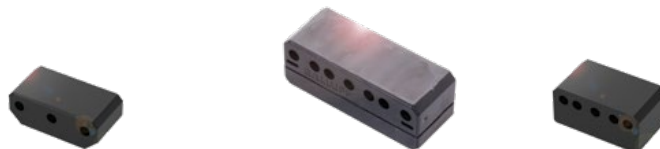

	BAM014M BTL5-P-3800-2	BAM014T BTL5-P-5500-2	BAM014Z BTL6-A-3801-2
Description	Standard free-floating magnet	Extended range free-floating magnet	Standard free floating magnet for BTL6-series tubular profile sensors
Material	POM	POM	POM
Dimension	37.6 x 14 x 20 mm	55 x 20 x 21 mm	37.6 x 18.3 x 21 mm

For additional magnet options, visit www.balluff.com

Connectivity

SINGLE-ENDED CORDSETS FOR SENSORS WITH 8-PIN M12 CONNECTIONS

M12 STRAIGHT



	BCC00YE BKS-S115-PU-02	BCC00YF BKS-S115-PU-05	BCC00YH BKS-S115-PU-10
Connection	M12 female, straight, 8-pin, A-coded	M12 female, straight, 8-pin, A-coded	M12 female, straight, 8-pin, A-coded
Cable	PUR shielded black, 2.00 m	PUR shielded black, 5.00 m	PUR shielded black, 10.00 m

For additional cordset and connector options, visit www.balluff.com

M12 ANGLED



	BCC00YU BKS-S116-PU-02	BCC00YW BKS-S116-PU-05	BCC00YY BKS0S116-PU-10
Connection	M12 female, angled, 8-pin, A-coded	M12 female, angled, 8-pin, A-coded	M12 female, angled, 8-pin, A-coded
Cable	PUR shielded black, 2.00 m	PUR shielded black, 5.00 m	PUR shielded black, 10.00 m

For additional cordset and connector options, visit www.balluff.com

Connectivity

SINGLE-ENDED CORDSETS FOR SENSORS WITH 8-PIN M16 CONNECTIONS

M16 STRAIGHT



	BCC00TU BKS-S 32M-02	BCC00TY BKS-S 32M-05	BCC00TZ BKS-S 32M-10
Connection	M16 female, straight, 8-pin	M16 female, straight, 8-pin	M16 female, straight, 8-pin
Cable	PUR shielded black, 2.00 m	PUR shielded black, 5.00 m	PUR shielded black, 10.00 m

For additional cordset and connector options, visit www.balluff.com

M16 ANGLED



	BCC00UR BKS-S 33M-02	BCC00UU BKS-S 33M-05	BCC00UW BKS-S33M-10
Connection	M16 female, angled, 8-pin	M16 female, angled, 8-pin	M16 female, angled, 8-pin
Cable	PUR shielded black, 2.00 m	PUR shielded black, 5.00 m	PUR shielded black, 10.00 m

For additional cordset and connector options, visit www.balluff.com

Connectivity

DOUBLE-ENDED CORDSETS FOR SENSORS WITH 4-PIN M12 CONNECTIONS

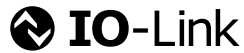

M12
STRAIGHT-STRAIGHT



	BCC05LY BCC M415-M414-3A-304-EX44T2-020	BCC05M1 BCC M415-M414-3A-304-EX44T2-050	BCC05M3 BCC M415-M424-3A-304-EX44T2-100
Connection 1	M12 female, straight, 5-pin, A-coded	M12 female, straight, 5-pin, A-coded	M12 female, straight, 5-pin, A-coded
Connection 2	M12 male, straight, 4-pin, A-coded	M12 male, straight, 4-pin, A-coded	M12 male, straight, 4-pin, A-coded
Cable	TPE yellow, 2.00 m	TPE yellow, 5.00 m	TPE yellow, 10.00 m

For additional cordset and connector options, visit www.balluff.com

M12
STRAIGHT-ANGLED



	BCC05P0 BCC M415-M424-3A-304-EX44T2-020	BCC05P2 BCC M415-M424-3A-304-EX44T2-050	BCC085U BCC M415-M424-3A-304-EX44T2-100
Connection 1	M12 female, straight, 5-pin	M12 female, straight, 5-pin	M12 female, straight, 5-pin
Connection 2	M12 male, angled, 4-pin	M12 male, angled, 4-pin	M12 male, angled, 4-pin
Cable	TPE yellow, 2.00 m	TPE yellow, 5.00 m	TPE yellow, 10.00 m

For additional cordset and connector options, visit www.balluff.com

Connectivity

CORDSETS FOR ETHERNET SENSORS

EtherNet/IP™

M12
STRAIGHT-RJ45



	BCC0E90 BCC M414-E894-8G-672-ES64N9-020	BCC0E8Z BCC M414-E894-8G-672-ES64N9-050	BCC0E91 BCC M414-E894-8G-672-ES64N9-100
Connection 1	M12 male, straight, 4-pin, D-coded	M12 male, straight, 4-pin, D-coded	M12 male, straight, 4-pin, D-coded
Connection 2	RJ45 male, 4-pin	RJ45 male, 4-pin	RJ45 male, 4-pin
Cable	TPE shielded teal, 2.00 m	TPE shielded teal, 5.00 m	TPE shielded teal, 10.00 m

For additional cordset and connector options, visit www.balluff.com

M12
STRAIGHT-STRAIGHT



	BCC09NN BCC M414-M414-6D-338-ES64N9-020	BCC09NP BCC M414-M414-6D-338-ES64N9-050	BCC09NR BCC M414-M414-6D-338-ES64N9-100
Connection 1	M12 male, straight, 4-pin, D-coded	M12 male, straight, 4-pin, D-coded	M12 male, straight, 4-pin, D-coded
Connection 2	M12 male, straight, 4-pin, D-coded	M12 male, straight, 4-pin, D-coded	M12 male, straight, 4-pin, D-coded
Cable	TPE shielded teal, 2.00 m	TPE shielded teal, 5.00 m	TPE shielded teal, 10.00 m

For additional cordset and connector options, visit www.balluff.com

M8
POWER CABLES



	BCC053U BCC M314-0000-10-003-EX44T2-020	BCC053W BCC M314-0000-10-003-EX44T2-050	BCC053Y BCC M314-0000-10-003-EX44T2-100
Connection	M8 female, straight, 4-pin, A-coded	M8 female, straight, 4-pin, A-coded	M8 female, straight, 4-pin, A-coded
Cable	TPE yellow, 2.00 m	TPE yellow, 5.00 m	TPE yellow, 10.00 m

For additional cordset and connector options, visit www.balluff.com

USA

Balluff Inc.
8125 Holton Drive
Florence, KY 41042
Phone: (859) 727-2200
Toll-free: 1-800-543-8390
Fax: (859) 727-4823
balluff@balluff.com

Canada

Balluff Canada, Inc.
2840 Argentinia Road, Unit #2
Mississauga, Ontario L5N 8G4
Phone: (905) 816-1494
Toll-free: 1-800-927-9654
Fax: (905) 816-1411
balluff.canada@balluff.ca

Mexico

Balluff de México SA de CV
Anillo Vial II Fray Junípero Serra No. 4416
Colonia La Vista Residencial.
Querétaro, Qro. CP76232
Phone: (+52 442) 212-4882
Fax: (+52 442) 214-0536
balluff.mexico@balluff.com

